

Codice	Descrizione	Note
A02_0_66730	PROTEZIONE MOTORE (340 _ 346)	
A02_1_77305	PROTEZIONE MOTORE (340 _ 346 _ 360)	
A.02.01.A0003_02	PROTEZIONI MOTORE (340_346_360)	
A.02.01.A0003_03	PROTEZIONI MOTORE (34_346_360)	
B01_0_66748	COMANDO FRIZIONE POWERSAFE	
B01_1_72788	COMANDO FRIZIONE POWERSAFE	
B01_2_77329	COMANDO FRIZIONE POWERSAFE	
B.01.01.A0001_03	COMANDO FRIZIONE POWERSAFE	
C01_0_66780	CILINDRO E FRIZIONE POWERSAFE	
C01_1_72820	CILINDRO E FRIZIONE POWERSAFE	
C.01.01.A0001_02	CILINDRO E FRIZIONE POWERSAFE	
D01_0_66794	GRUPPO FILTRO POWERSAFE	
D01_1_77361	GRUPPO FILTRO POWERSAFE	
D.01.01.A0001_02	GRUPPO E FILTRO POWERSAFE	
D.01.01.A0003_03	GRUPPO E FILTRO POWERSAFE	
E01_0_66804	MOZZI FRIZIONE POWERSAFE	
E01_1_77371	MOZZI FRIZIONE POWERSAFE	
F01_0_66821	FLANGE MOTORE	
F01_1_77388	FLANGE MOTORE	
G02_0_66903	SCATOLA CAMBIO (340_346)	
H03_0_66965	INGRANAGGI CAMBIO (340_346)	
H03_1_77469	INGRANAGGI CAMBIO (340_346_360)	
H.03.02.A0003_02	INGRANAGGI CAMBIO (340-346-360)	
H.03.02.A0003_03	INGRANAGGI CAMBIO	
I03_0_67089	ASSE RUOTE (340)	
J03_0_67191	PIANTONE (340_346)	
J03_1_77552	PIANTONE (340_346_360)	
J03_2_77555	PIANTONE (340_346_360)	
K03_0_67265	MANUBRIO (340_346)	
K03_1_77574	MANUBRIO (340_346_360)	
L03_0_67358	COMANDI SUL MANUBRIO (330_340_346)	
L03_1_77607	COMANDI SUL MANUBRIO (330_340_346_360)	
L.03.01.A0003_02	COMANDI SUL MANUBRIO (330_338_340_346_360)	
M03_0_67475	COMANDI (340_346)	

Codice	Descrizione	Note
M03_1_77650	COMANDI (340_346_360)	
N02_0_67525	FRENI (330_340_346)	
N02_1_77691	FRENI (330_340_346_360)	
N.02.01.A0003_02	FRENI (330_338_340_346_360)	
P01_0_67539	RUOTE	
P01_1_81340	RUOTE	
Q01_0_67569	AVVIAMENTO ELETTRICO	
Q01_1_81859	AVVIAMENTO ELETTRICO	
R01_0_67594	ADESIVE	
R02_0_67613	ADESIVE	
R02_1_82042	ADESIVE	
R.02.01.A0003_02	ADESIVE	
S.01.01.A0027_00	KIT COFANO MOTORE	

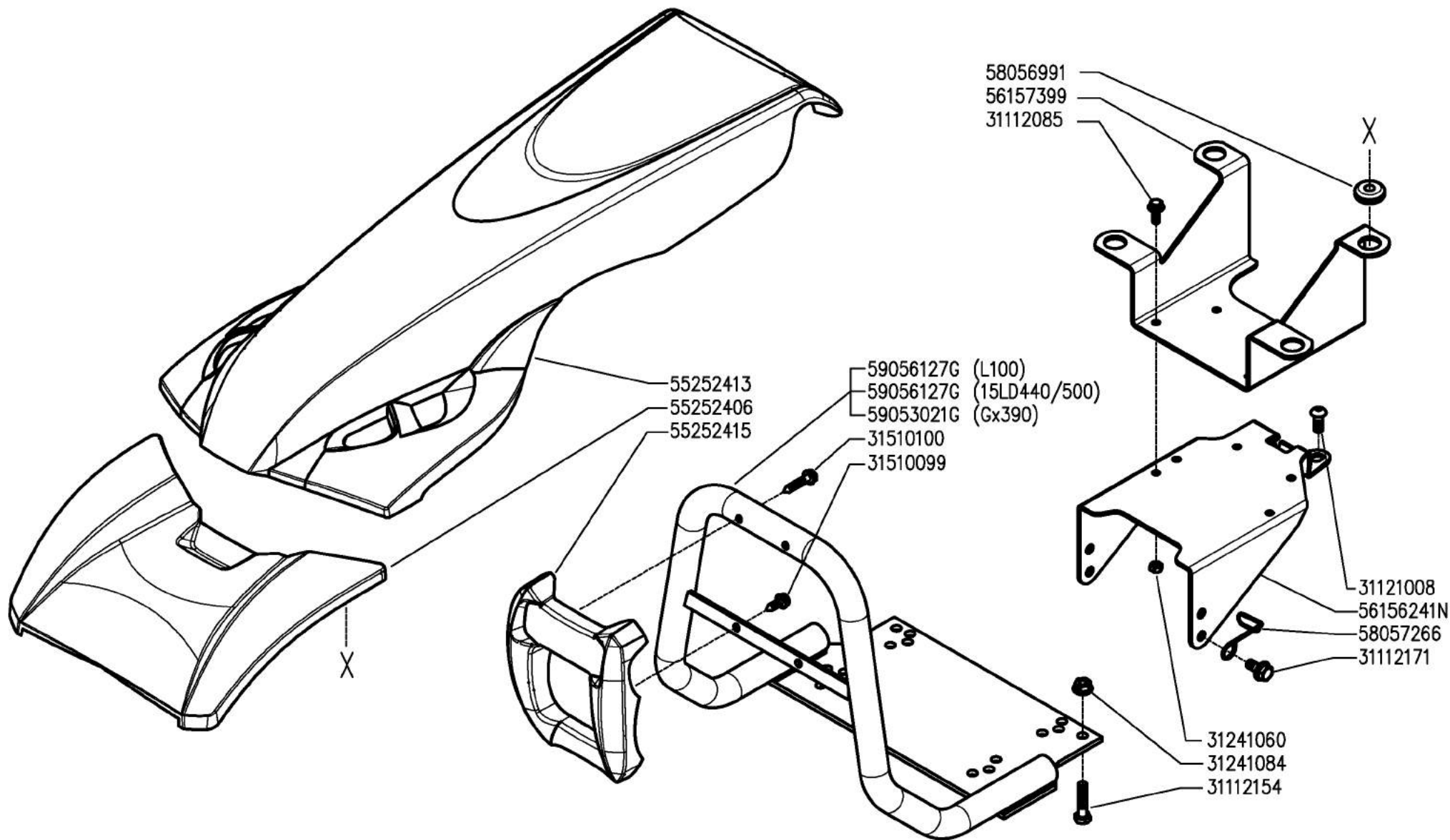

FERRARI

300 serie PS
PowerSafe®

ENGINE PROTECTIONS
PROTECCIONES MOTOR

PROTEZIONI MOTORE
(340 / 346)

PROTECTIONS MOTEUR
MOTORSCHUTZ

DALLA MACCHINA
DE LA MAQUINA
DE LA MACHINA
FROM THE MACHINE
AB DER MASCHINE

N.

A02

Rev.

0

05/2009

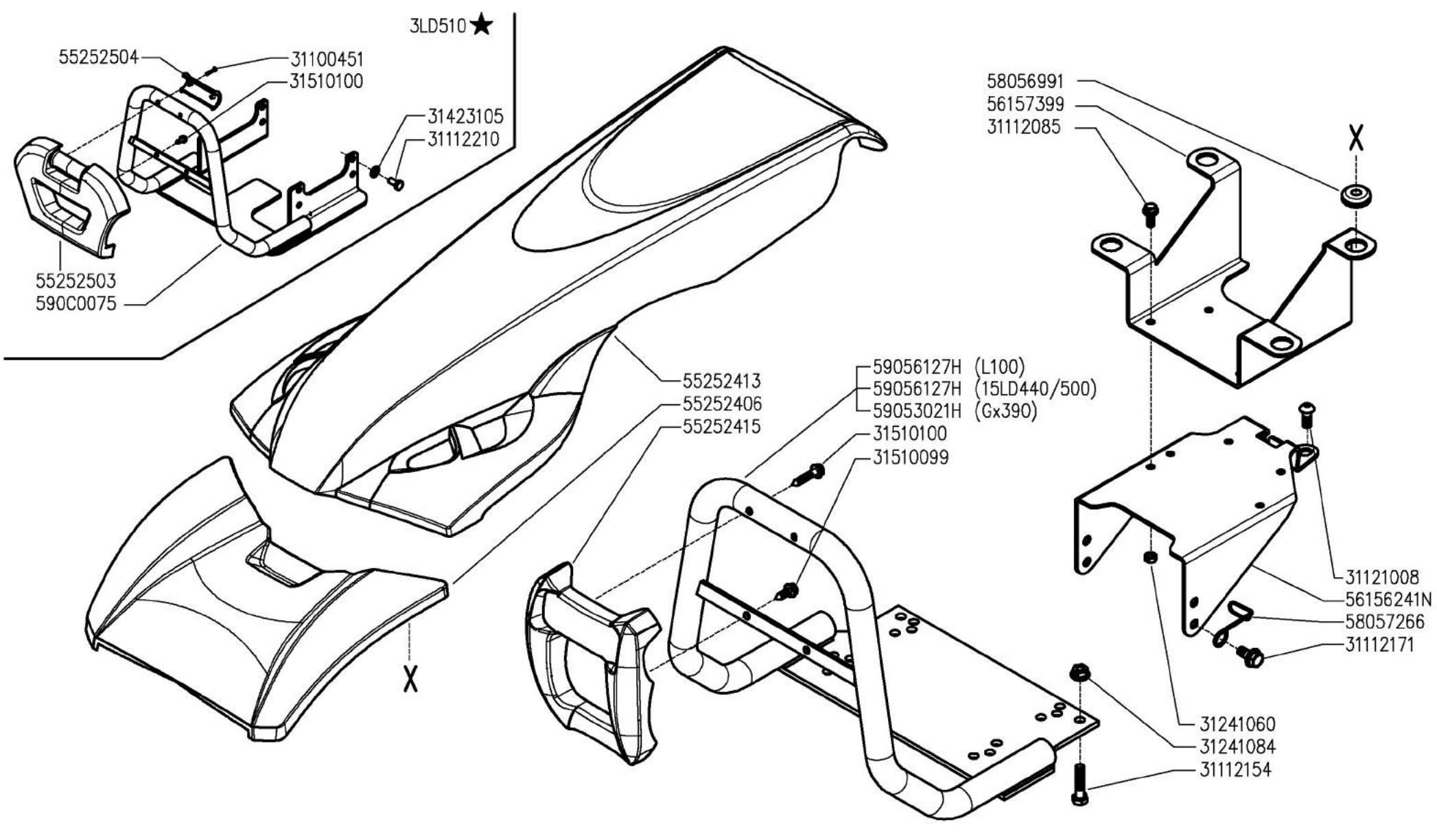

300 serie PS
PowerSafe®

ENGINE PROTECTIONS
PROTECCIONES MOTOR

PROTEZIONI MOTORE
(340-346-360 ★)

PROTECCIONES MOTEUR
MOTORSCHUTZ

DALLA MACCHINA
DE LA MAQUINA
DE LA MACHINA
FROM THE MACHINE
AB DER MASCHINE

★ N.

AGGIORNAMENTO
APLAZAMIENTO
MISE A JOUR
REVISION
ANPASSUNG

A02

11/2010

Rev. 1

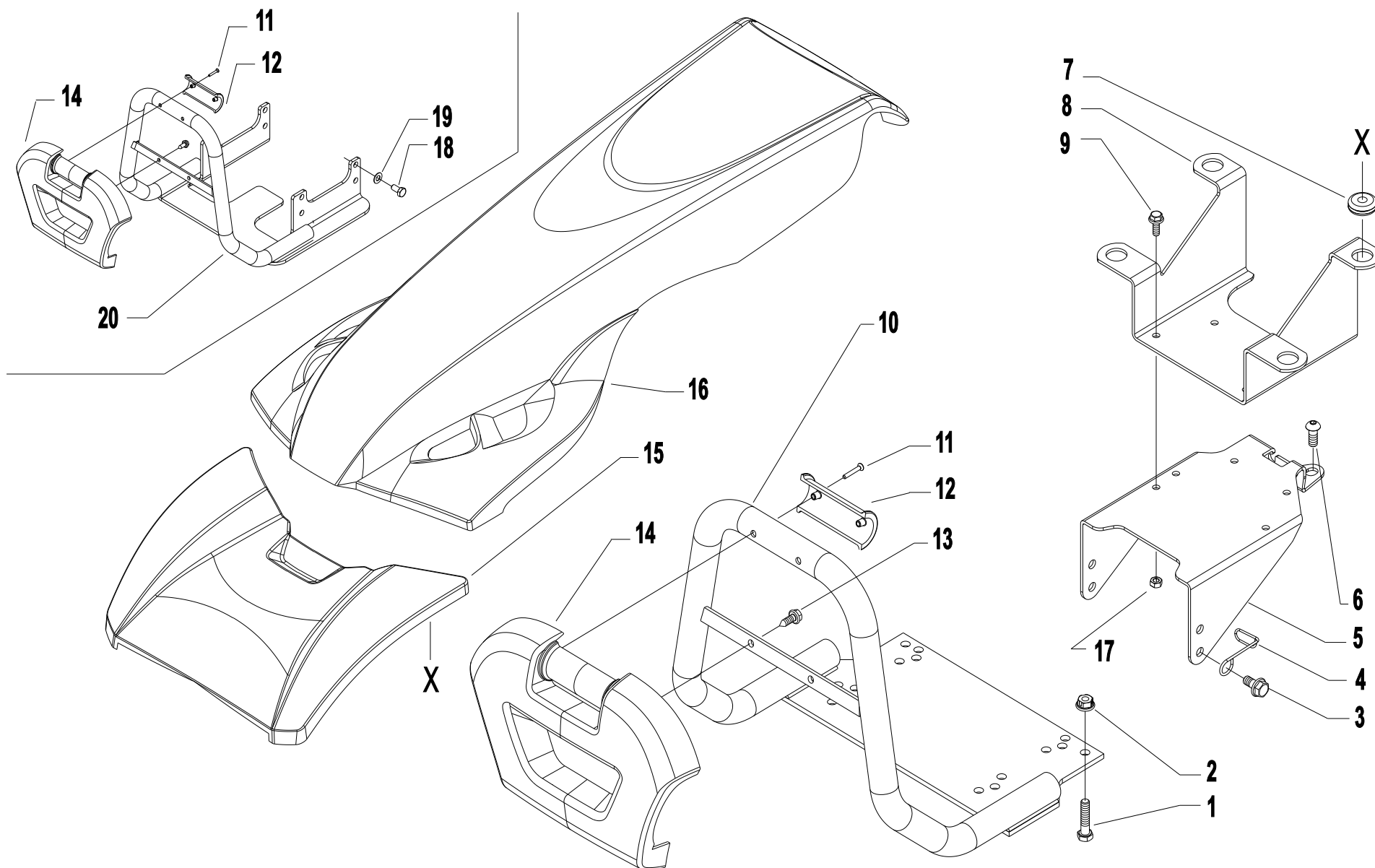

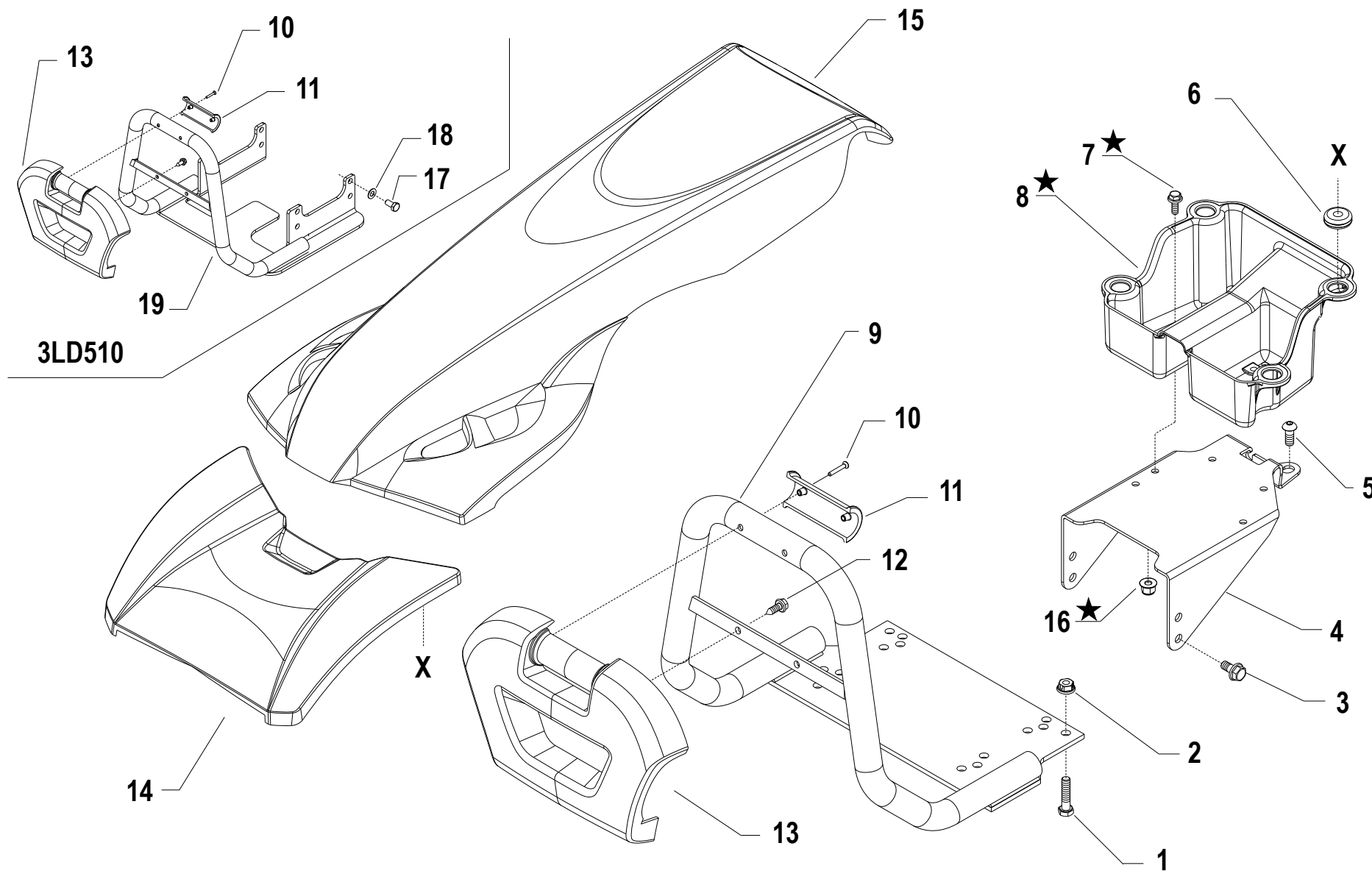

i = info - stop 2 sec. ★ = new part

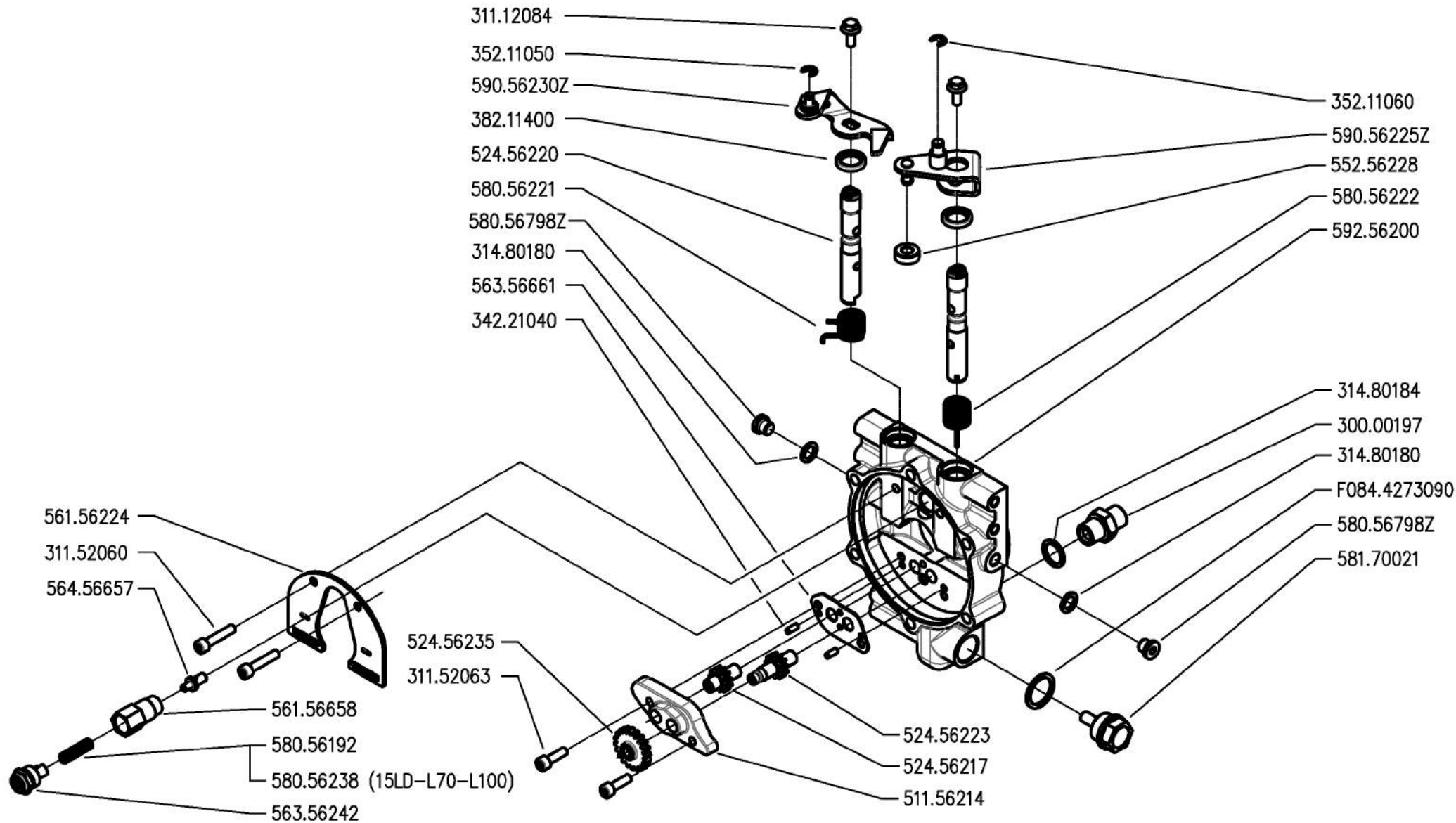

300 serie PS
 PowerSafe®

COMANDO FRIZIONE POWERSAFE

POWERSAFE CLUTCH CONTROL
 CONTROL EMBRAGUE POWERSAFE

CONTRÔLE EMBRAYAGE POWERSAFE
 REGELUND POWERSAFE KUPPLUNG

DALLA MACCHINA
 DE LA MAQUINA
 DE LA MACHINA
 FROM THE MACHINE
 AB DER MASCHINE

N.

Rev.	0
B01	
05/2009	

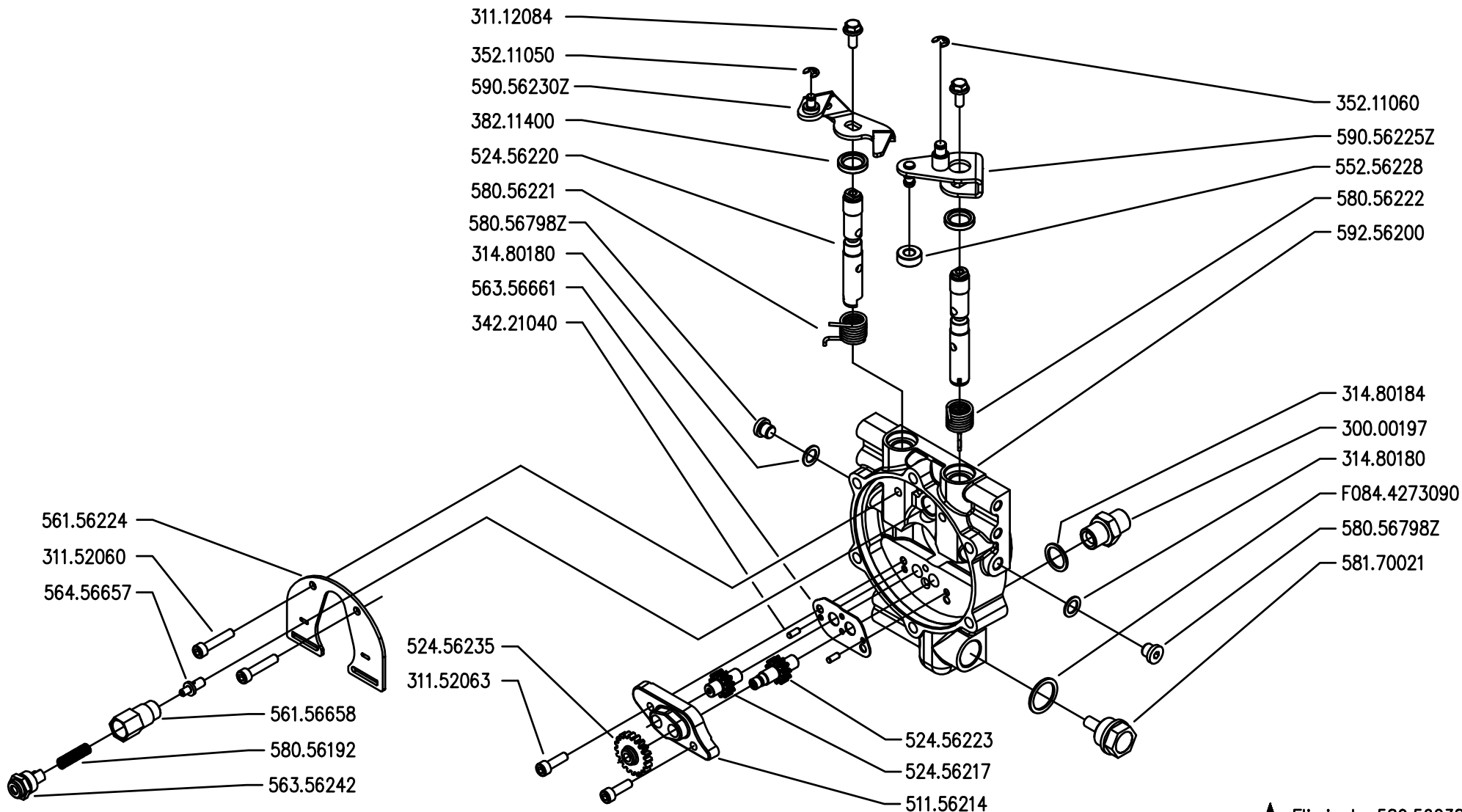

★ Eliminato 580.56238



300 serie PS
 PowerSafe®

COMANDO FRIZIONE POWERSAFE

POWERSAFE CLUTCH CONTROL
 CONTROL EMBRAGUE POWERSAFE

CONTRÔLE EMBRAYAGE POWERSAFE
 REGELUND POWERSAFE KUPPLUNG

DALLA MACCHINA
 DE LA MAQUINA
 DE LA MACHINA
 FROM THE MACHINE
 AB DER MASCHINE



N.

852604

B01

Rev.
 1

04/2010

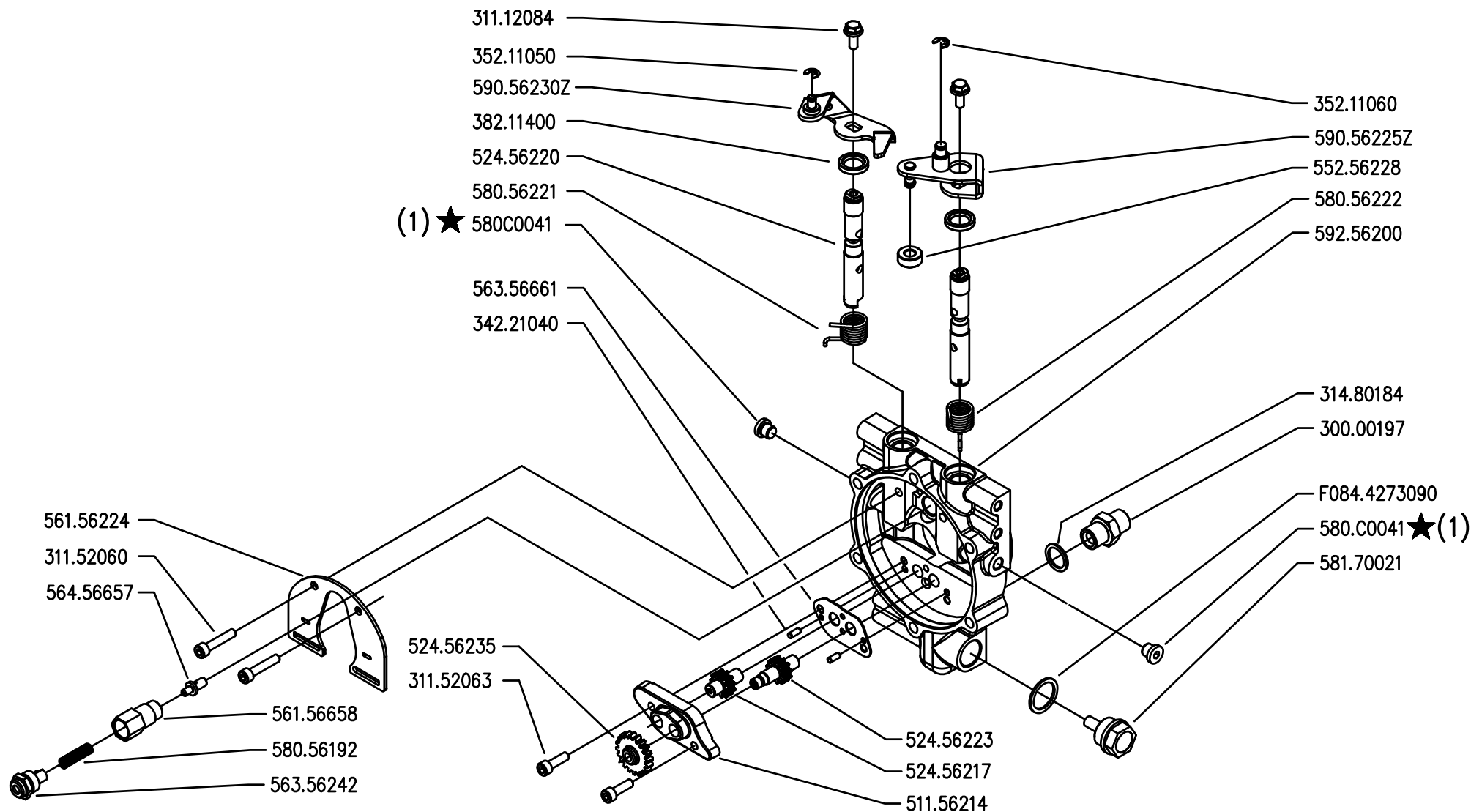

(1) sostituisce (580.56798Z + 314.80180)



300 serie PS
 PowerSafe®

COMANDO FRIZIONE POWERSAFE

POWERSAFE CLUTCH CONTROL
 CONTROL EMBRAGUE POWERSAFE

CONTRÔLE EMBRAYAGE POWERSAFE
 REGELUND POWERSAFE KUPPLUNG

DALLA MACCHINA
 DE LA MAQUINA
 DE LA MACHINA
 FROM THE MACHINE
 AB DER MASCHINE



N.

AGGIORNAMENTO
 APLAZAMIENTO
 MISE A JOUR
 REVISION
 ANPASSUNG

B01

Rev.
 2

09/2010

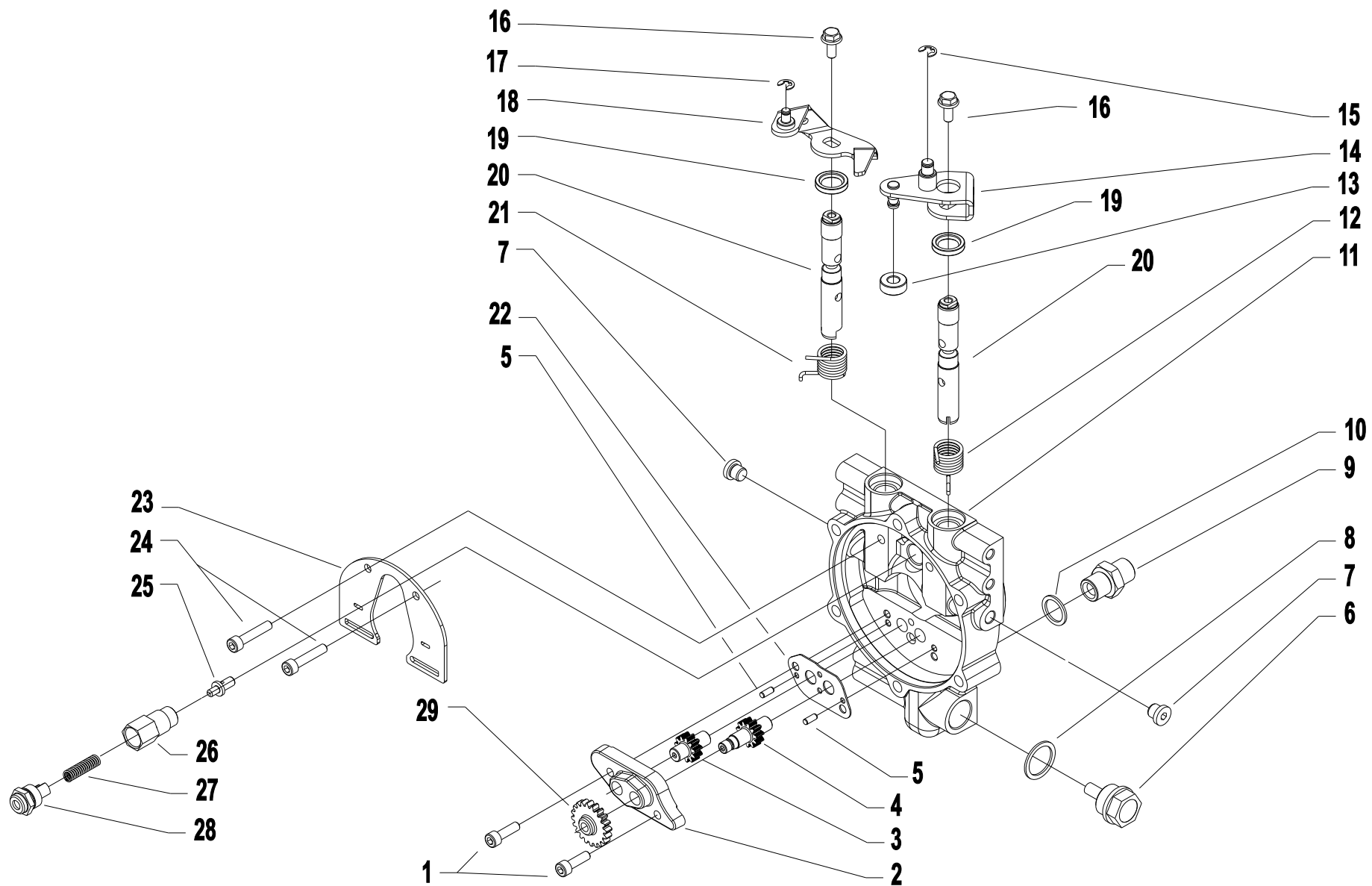

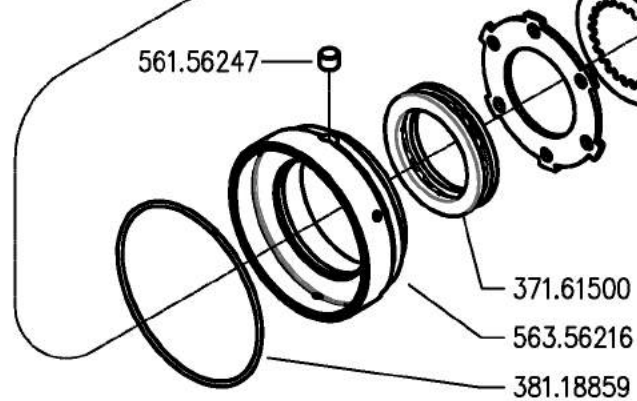
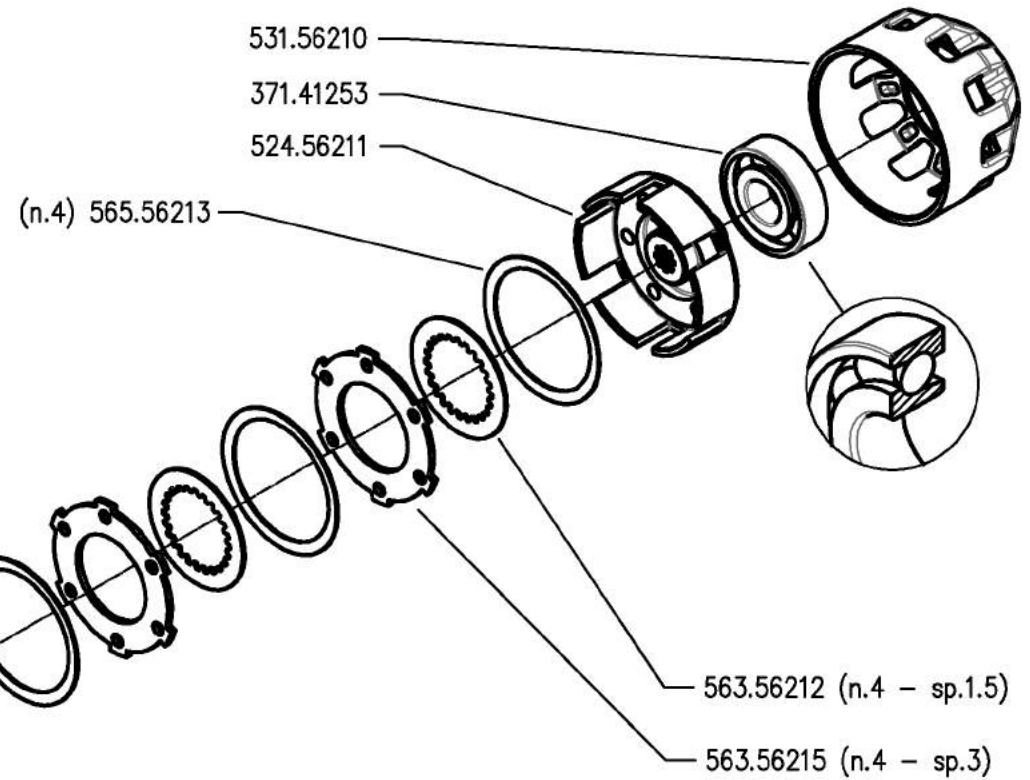
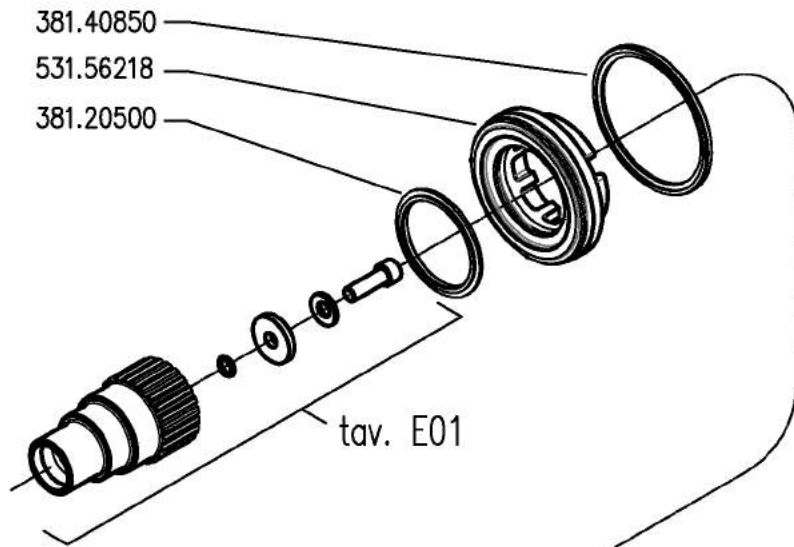

300 serie PS
PowerSafe®

CILINDRO E FRIZIONE POWERSAFE

CYLINDER AND POWERSAFE CLUTCH

CILINDRO Y EMBRAGUE POWERSAFE

CYLINDER ET EMBRAYAGE POWERSAFE

ZILINDER UND POWERSAFE KUPPLUNG

DALLA MACCHINA
DE LA MAQUINA
DE LA MACHINA
FROM THE MACHINE
AB DER MASCHINE

N.

C01	Rev. 0
	05/2009

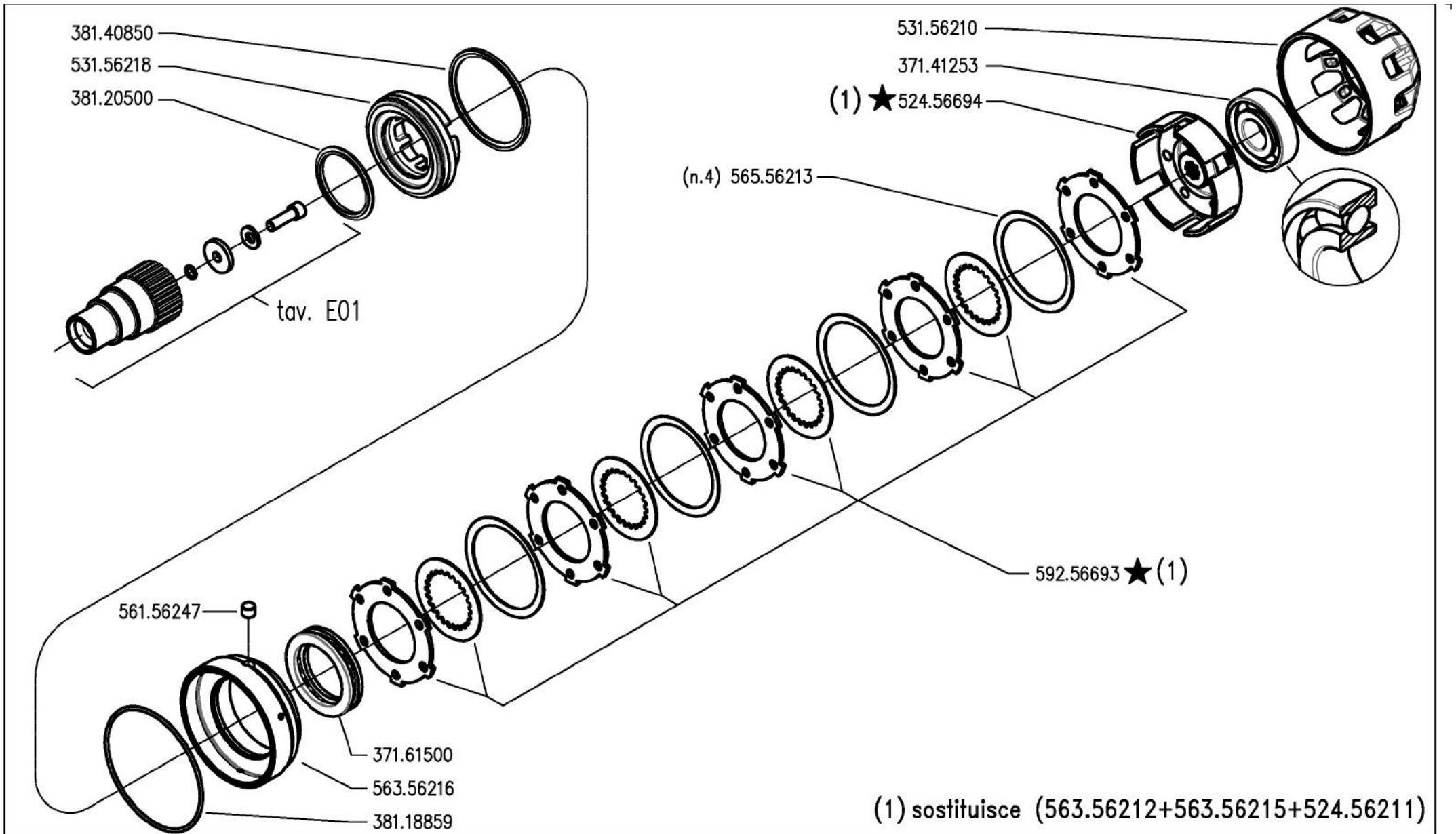

300 serie PS
PowerSafe®

CILINDRO E FRIZIONE POWERSAFE

CYLINDER AND POWERSAFE CLUTCH

CILINDRO Y EMBRAGUE POWERSAFE

CYLINDER ET EMBRAYAGE POWERSAFE

ZILINDER UND POWERSAFE KUPPLUNG

DALLA MACCHINA
DE LA MAQUINA
DE LA MACHINA
FROM THE MACHINE
AB DER MASCHINE

★ N.

852604

C01

04/2010

Rev.

1

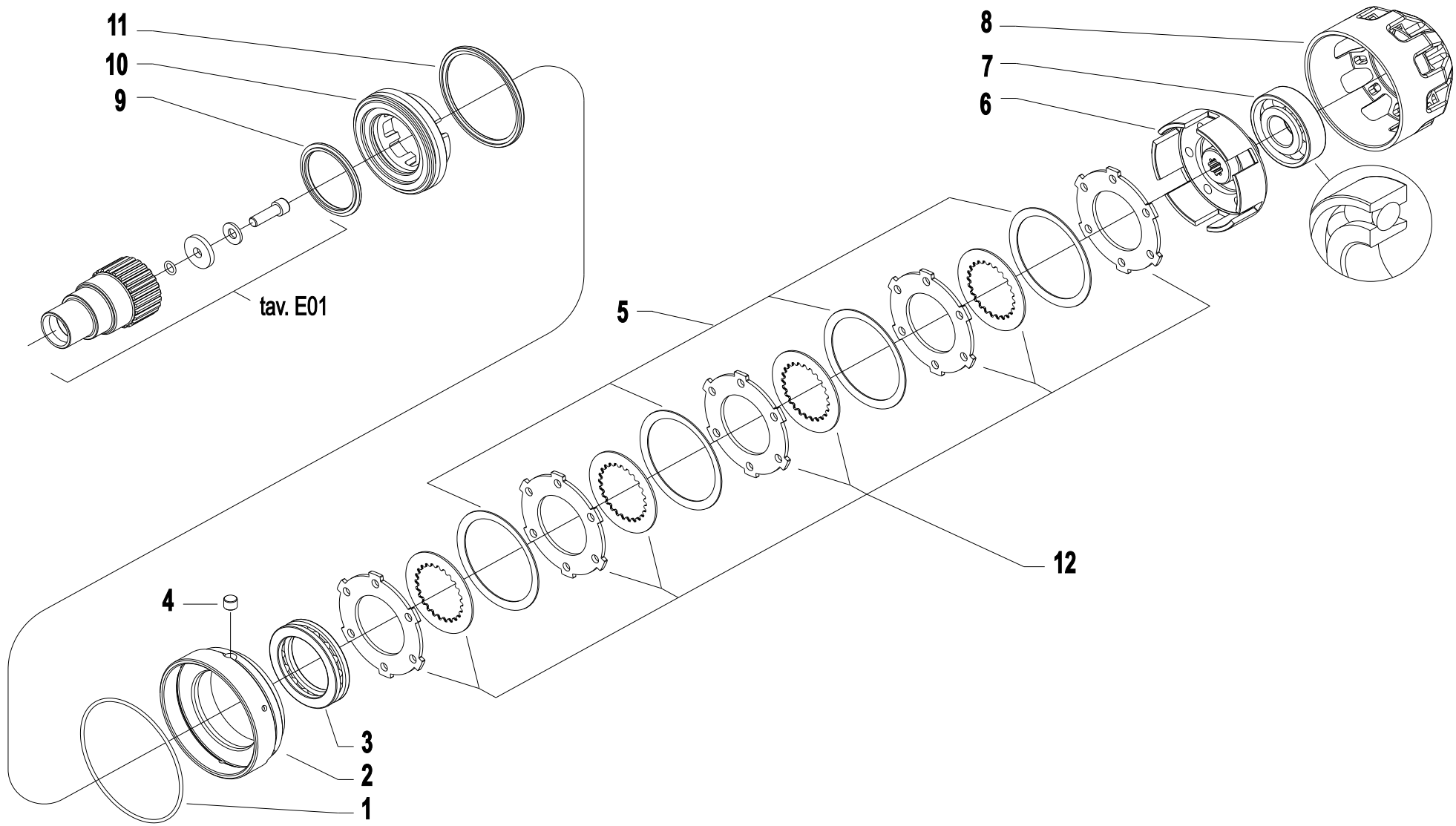

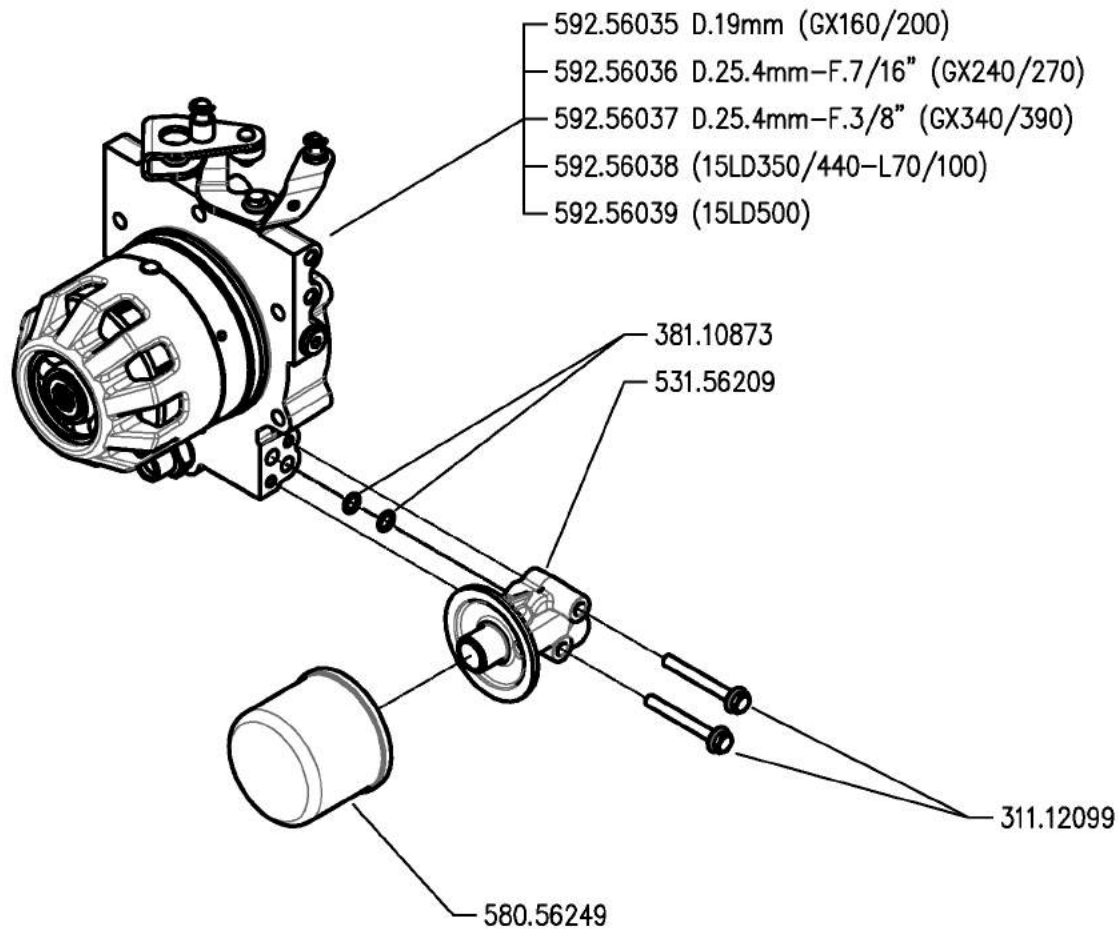

300 serie PS
PowerSafe®

GRUPPO FILTRO POWERSAFE

POWERSAFE FILTER UNIT

FILTRO POWERSAFE

FILTRE POWERSAFE

POWERSAFE FILTER

DALLA MACCHINA
 DE LA MAQUINA
 DE LA MACHINA
 FROM THE MACHINE
 AB DER MASCHINE

N.

D01

Rev.

0

05/2009

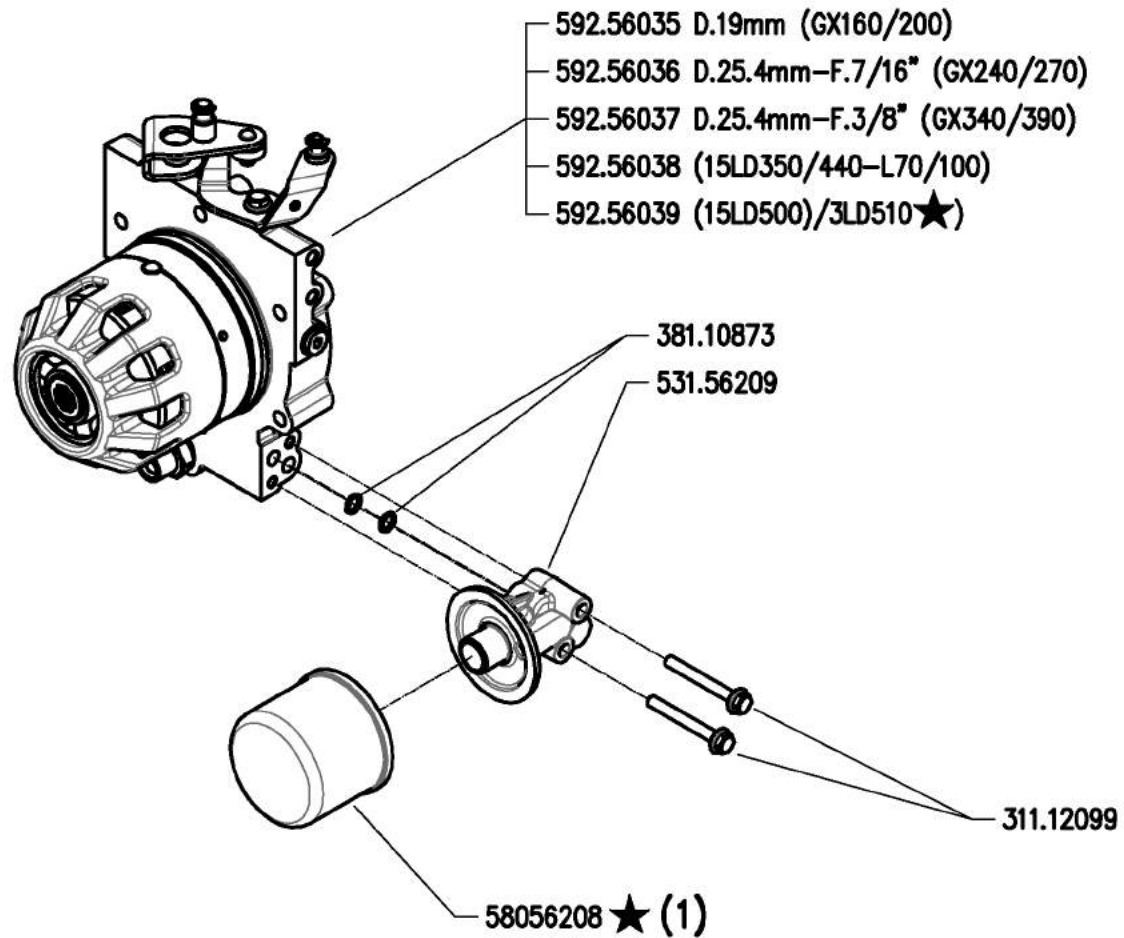

(1) sostituisce 580.56249



300 serie PS
 PowerSafe®

GRUPPO E FILTRO POWERSAFE

POWERSAFE FILTER AND UNIT
 FILTRO POWERSAFE

FILTRE POWERSAFE
 POWERSAFE FILTER

DALLA MACCHINA
 DE LA MAQUINA
 DE LA MACHINA
 FROM THE MACHINE
 AB DER MASCHINE

★ N.

AGGIORNAMENTO
 APLAZAMIENTO
 MISE A JOUR
 REVISION
 ANPASSUNG

D01

11/2010

Rev.

1

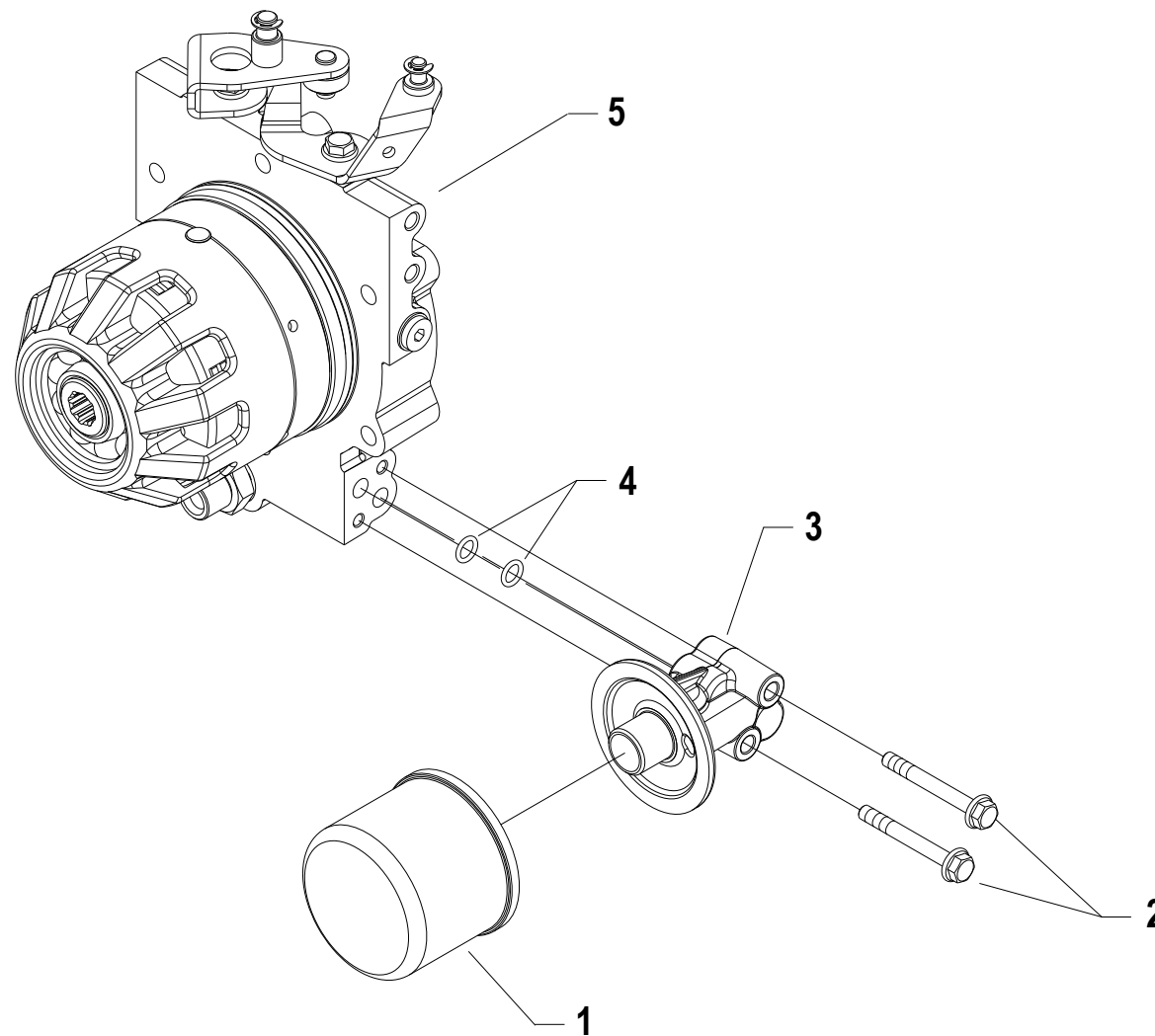

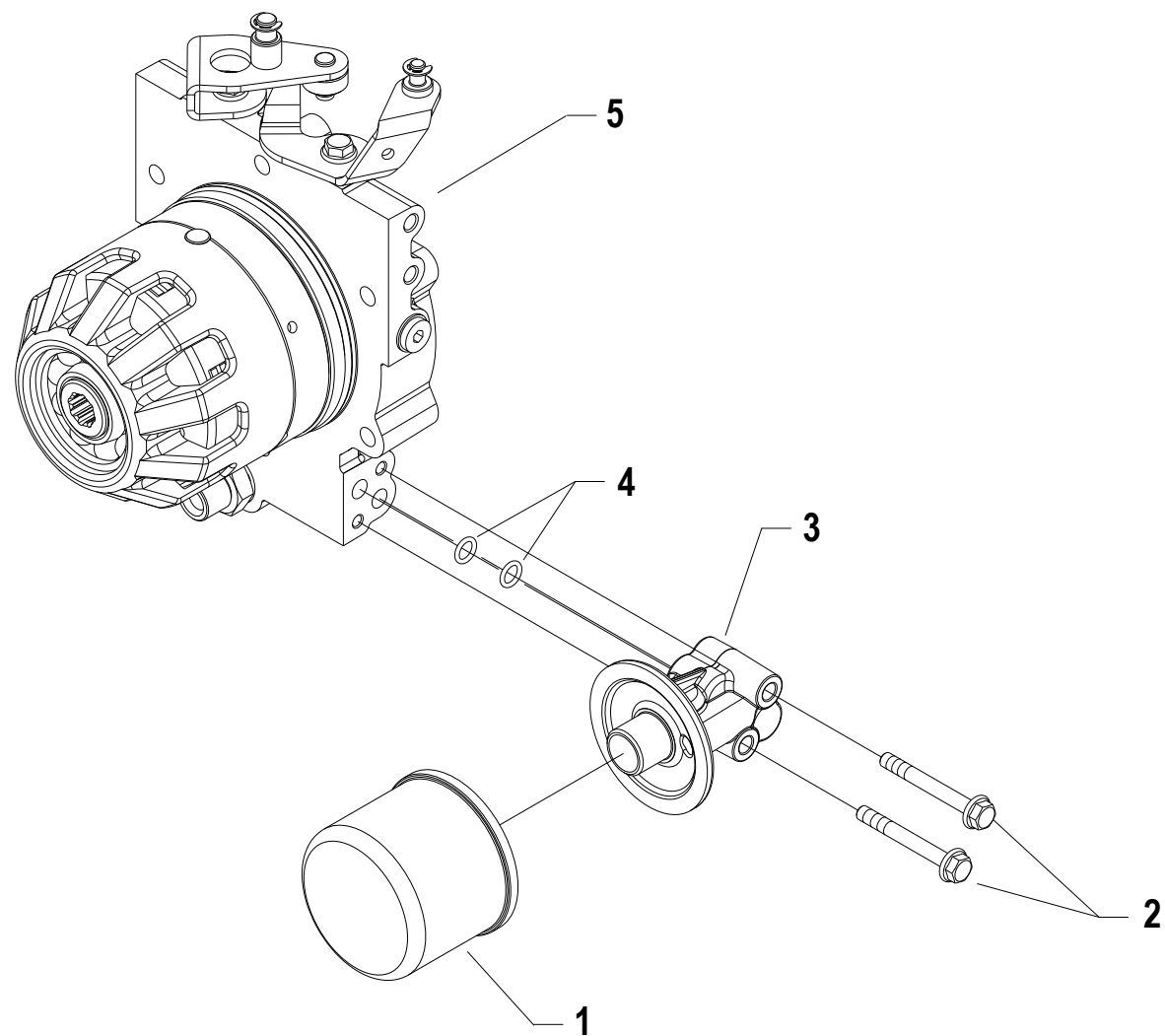

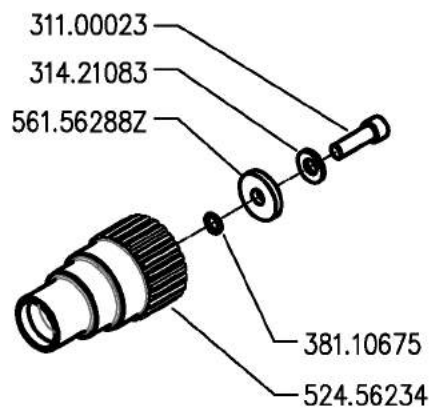

GX 160-200

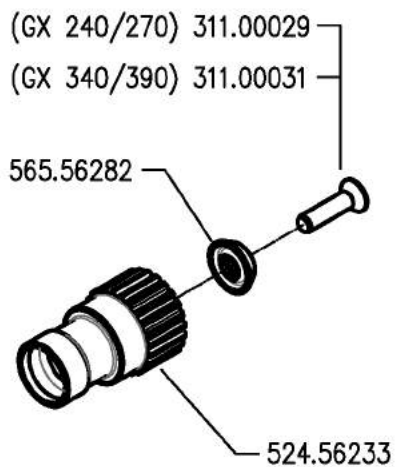

GX 240-270-340-390

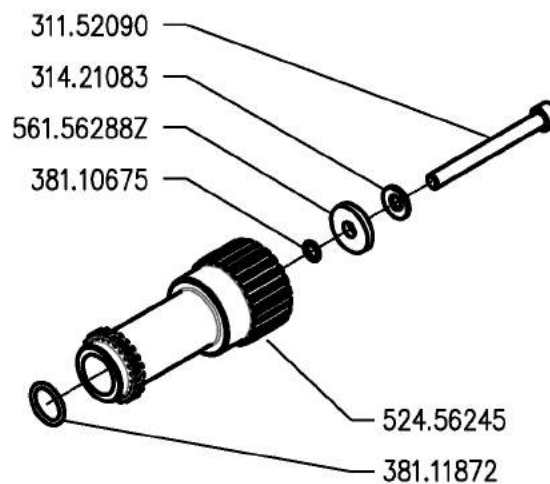

15LD350-440 - L70-100

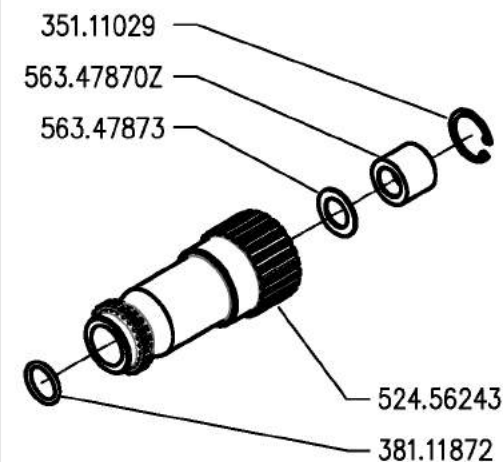

15LD500

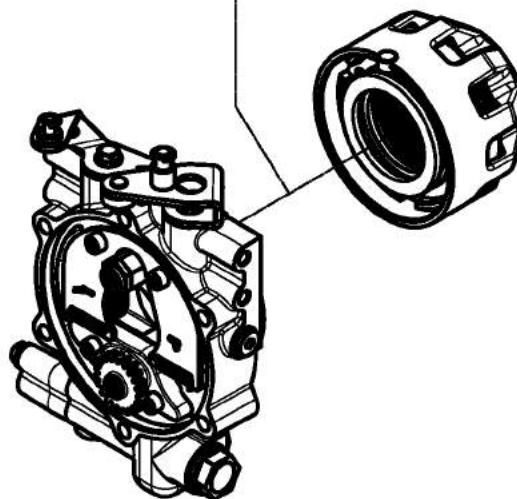

300 serie PS
PowerSafe®

MOZZI FRIZIONE POWERSAFE

POWERSAFE CLUTCH HUBS
CUBOS EMBRAGUE POWERSAFE

MOYEURS EMBRAYAGE POWERSAFE
NABEN POWERSAFE KUPPLUNG

DALLA MACCHINA
DE LA MAQUINA
DE LA MACHINA
FROM THE MACHINE
AB DER MASCHINE

N.

E01

Rev.

0

05/2009

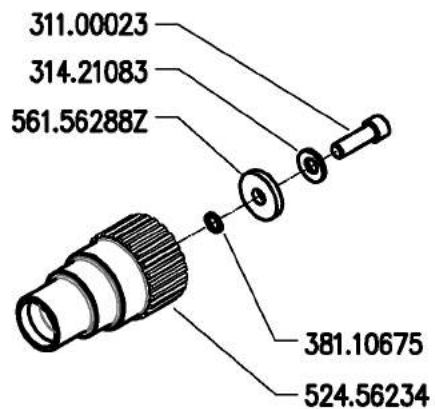

GX 160-200

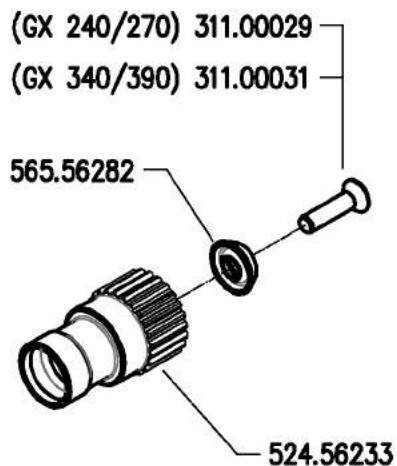

GX 240-270-340-390

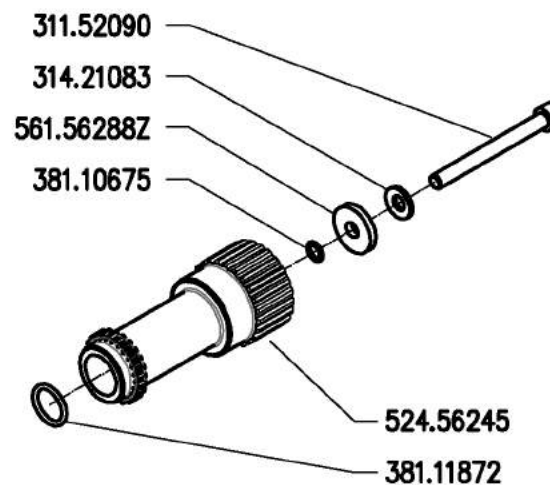

15LD350-440 - L70-100

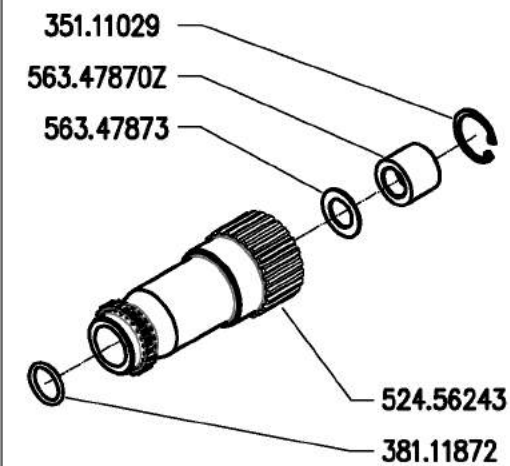

15LD500-3LD510 ★

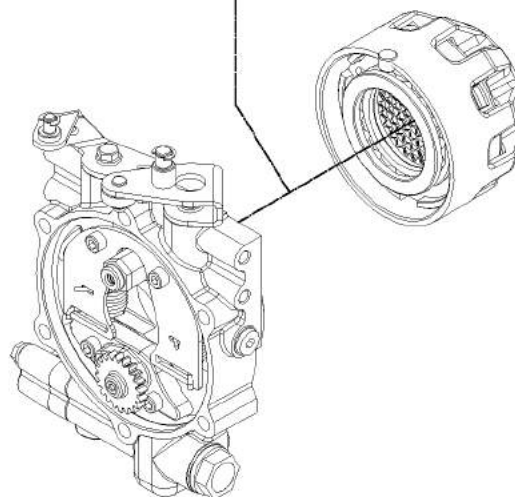

MOZZI FRIZIONE POWERSAFE

POWERSAFE CLUTCH HUBS
CUBOS EMBRAGUE POWERSAFE

MOYEURS EMBRAYAGE POWERSAFE
NABEN POWERSAFE KUPPLUNG

DALLA MACCHINA
DE LA MAQUINA
DE LA MACHINA
FROM THE MACHINE
AB DER MASCHINE

★ N.

AGGIORNAMENTO
APLAZAMIENTO
MISE A JOUR
REVISION
ANPASSUNG

E01

11/2010

Rev.

1



300 serie PS
PowerSafe®

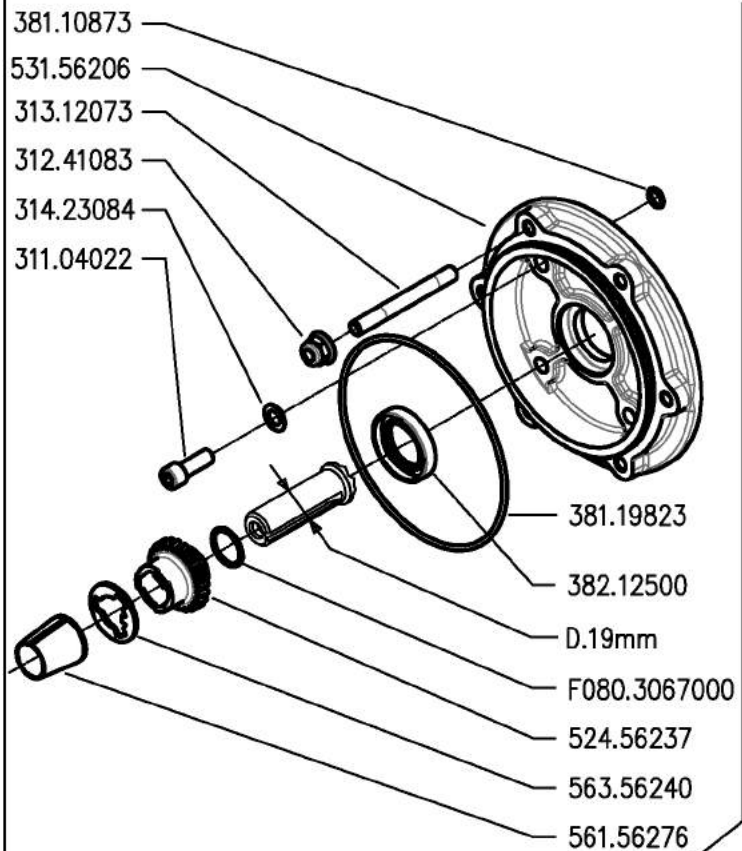

GX 160-200

GX 240-270-340-390

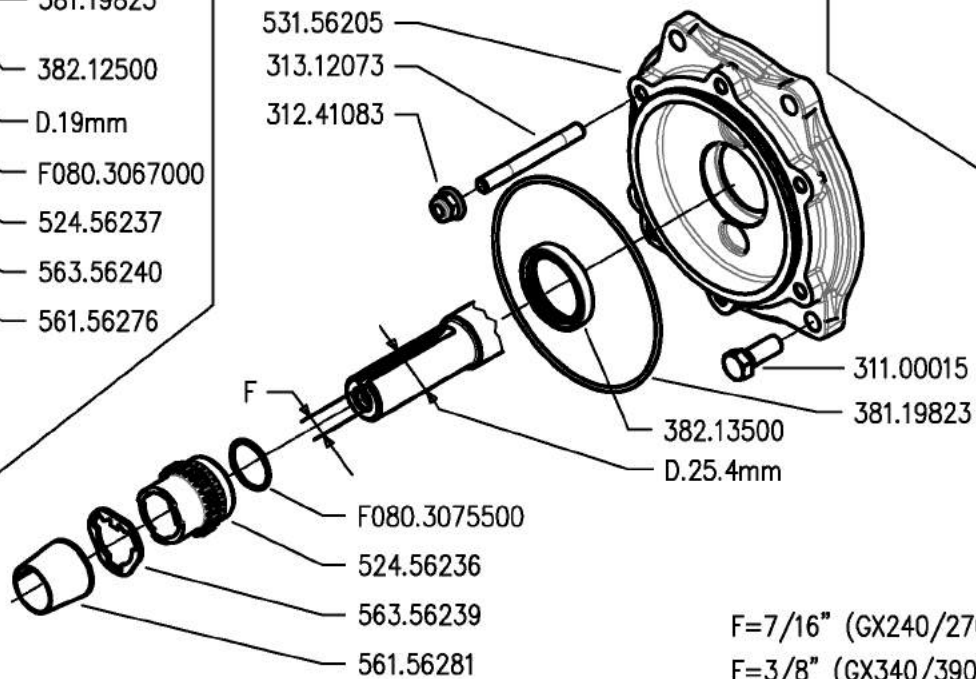

F=7/16" (GX240/270)

F=3/8" (GX340/390)

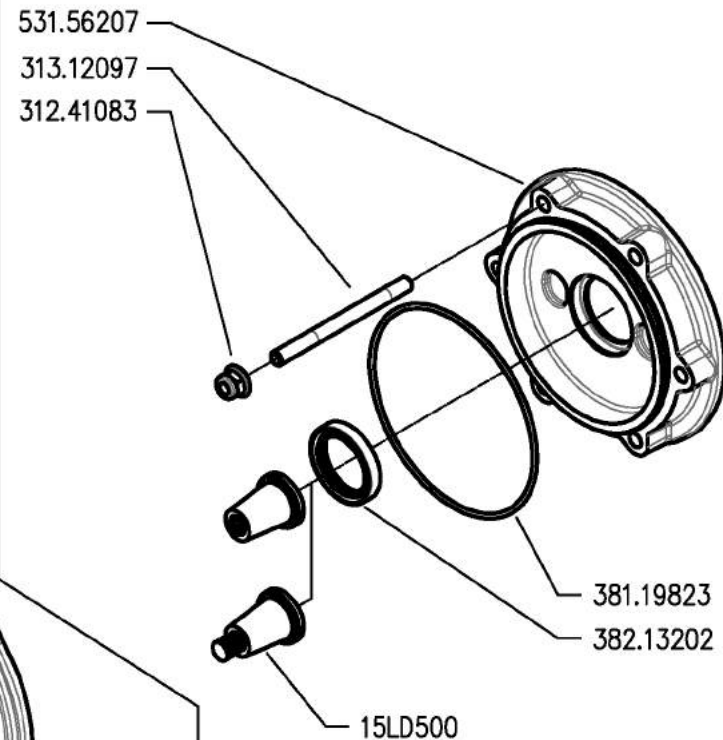

15LD350-440-500
L70-100



300 serie PS
PowerSafe®

ENGINE FLANGES

BRIDAS MOTOR

FLANGIE MOTORE

BRIDES MOTEUR

MOTOR FLANSCH

DALLA MACCHINA
DE LA MAQUINA
DE LA MACHINA
FROM THE MACHINE
AB DER MASCHINE

N.

F01 0

05/2009

Rev.

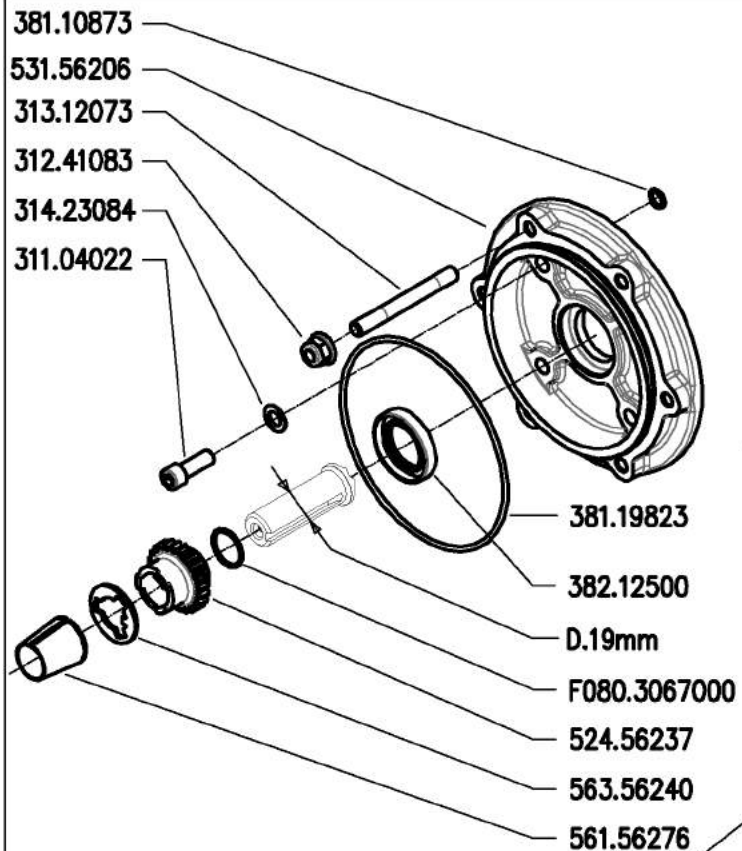

GX 160-200

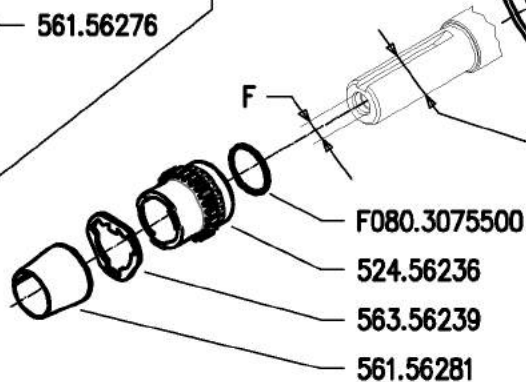

GX 240-270-340-390

F=7/16" (GX240/270)
F=3/8" (GX340/390)

★ 3LD510

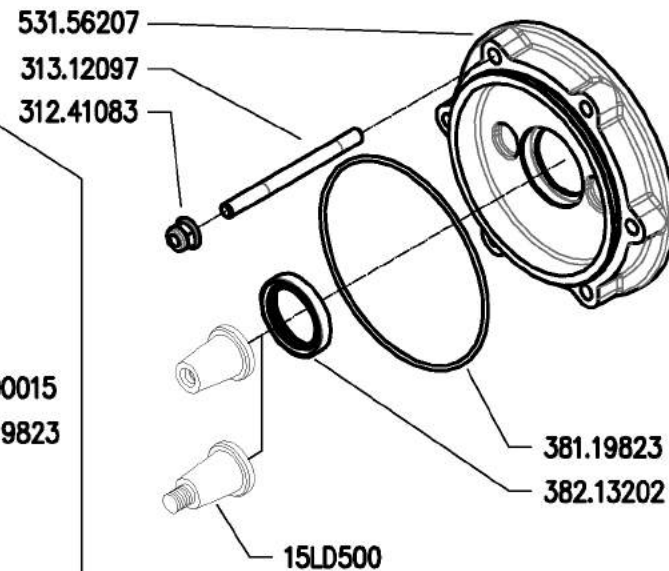
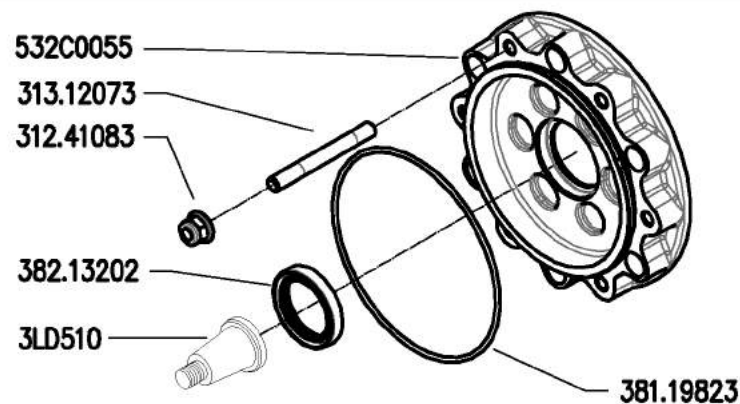

15LD350-440-500
L70-100



300 serie PS
PowerSafe®

ENGINE FLANGES

BRIDAS MOTOR

FLANGIE MOTORE

BRIDES MOTEUR

MOTOR FLANSCH

DALLA MACCHINA
DE LA MAQUINA
DE LA MACHINA
FROM THE MACHINE
AB DER MASCHINE

★ N.

AGGIORNAMENTO
APLAZAMIENTO
MISE A JOUR
REVISION
ANPASSUNG

F01

11/2010

Rev.

1

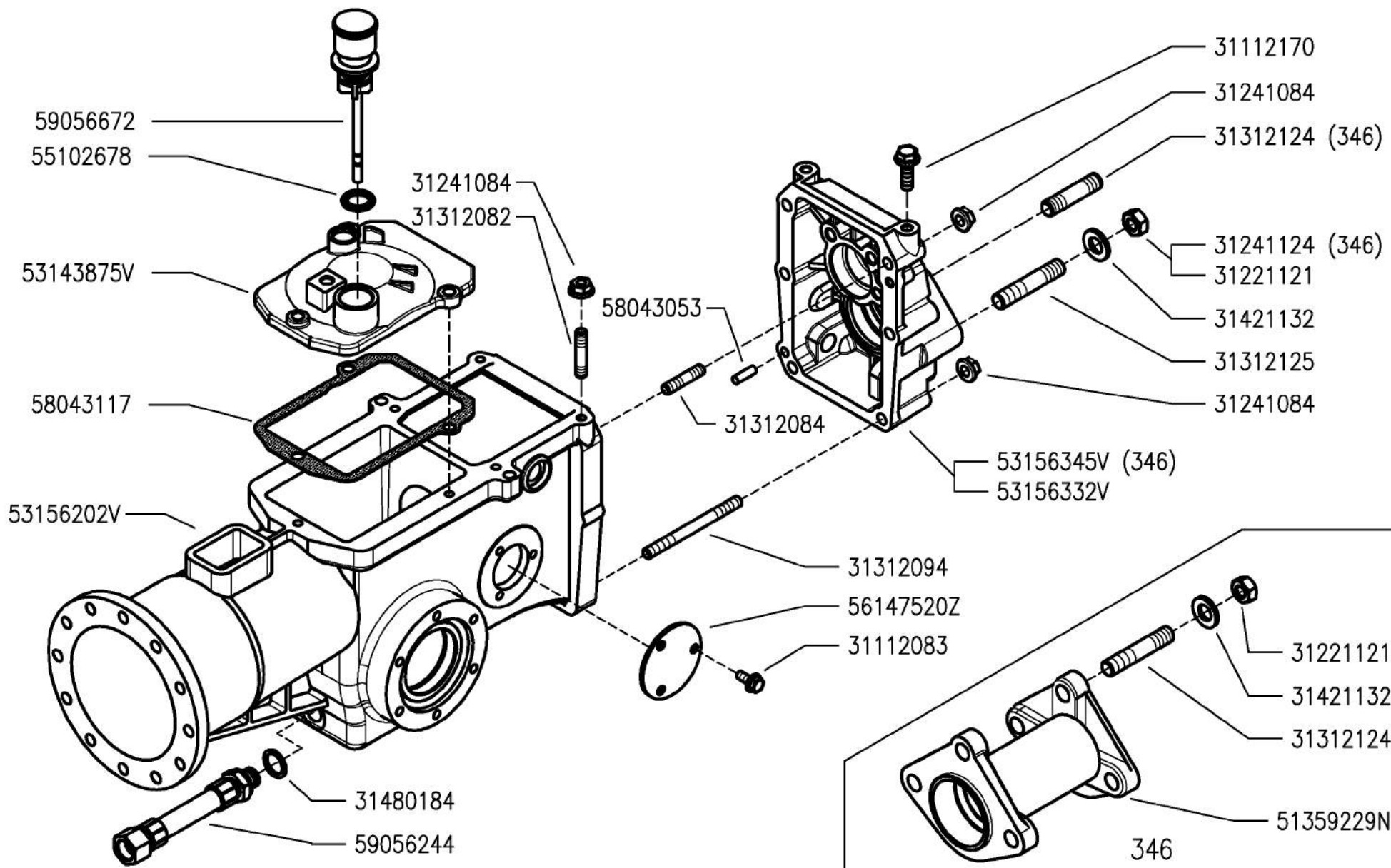

300 serie PS
PowerSafe®

GEARBOX
CAJA DE CAMBIO

SCATOLA CAMBIO
(340-346)

BOITE DE VITESSES
WECHSELGETRIEBE

DALLA MACCHINA
DE LA MAQUINA
DE LA MAQUINA
FROM THE MACHINE
AB DER MASCHINE

N.

G02
05/2009

Rev. 0

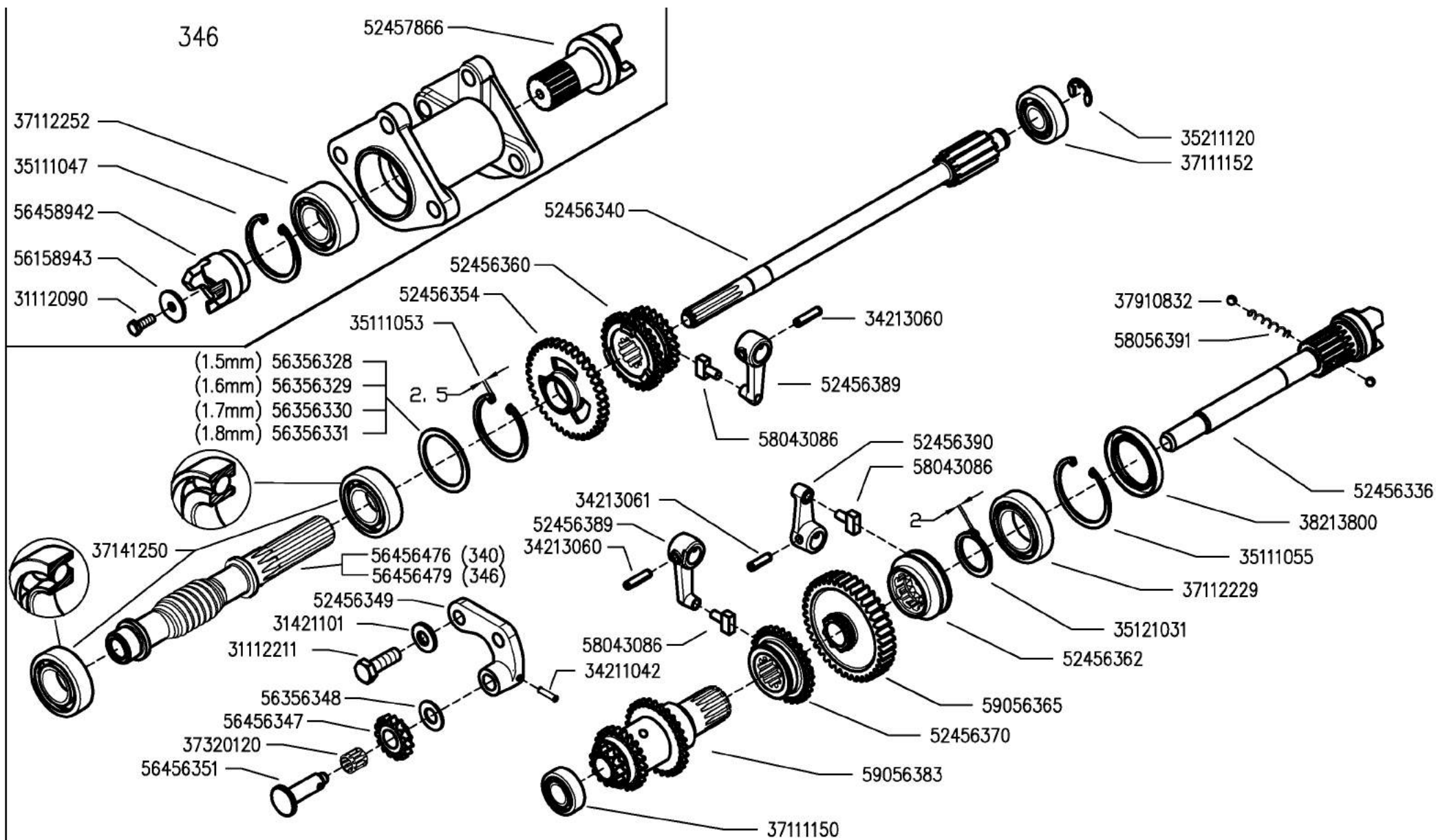

300 serie PS
PowerSafe®

GEARS
ENGRANAJES

INGRANAGGI CAMBIO
(340-346)

ENGRANAGES
ZÄHRÄDER

DALLA MACCHINA
DE LA MAQUINA
DE LA MACHINA
FROM THE MACHINE
AB DER MASCHINE

N.

Rev.	0
H03	
05/2009	

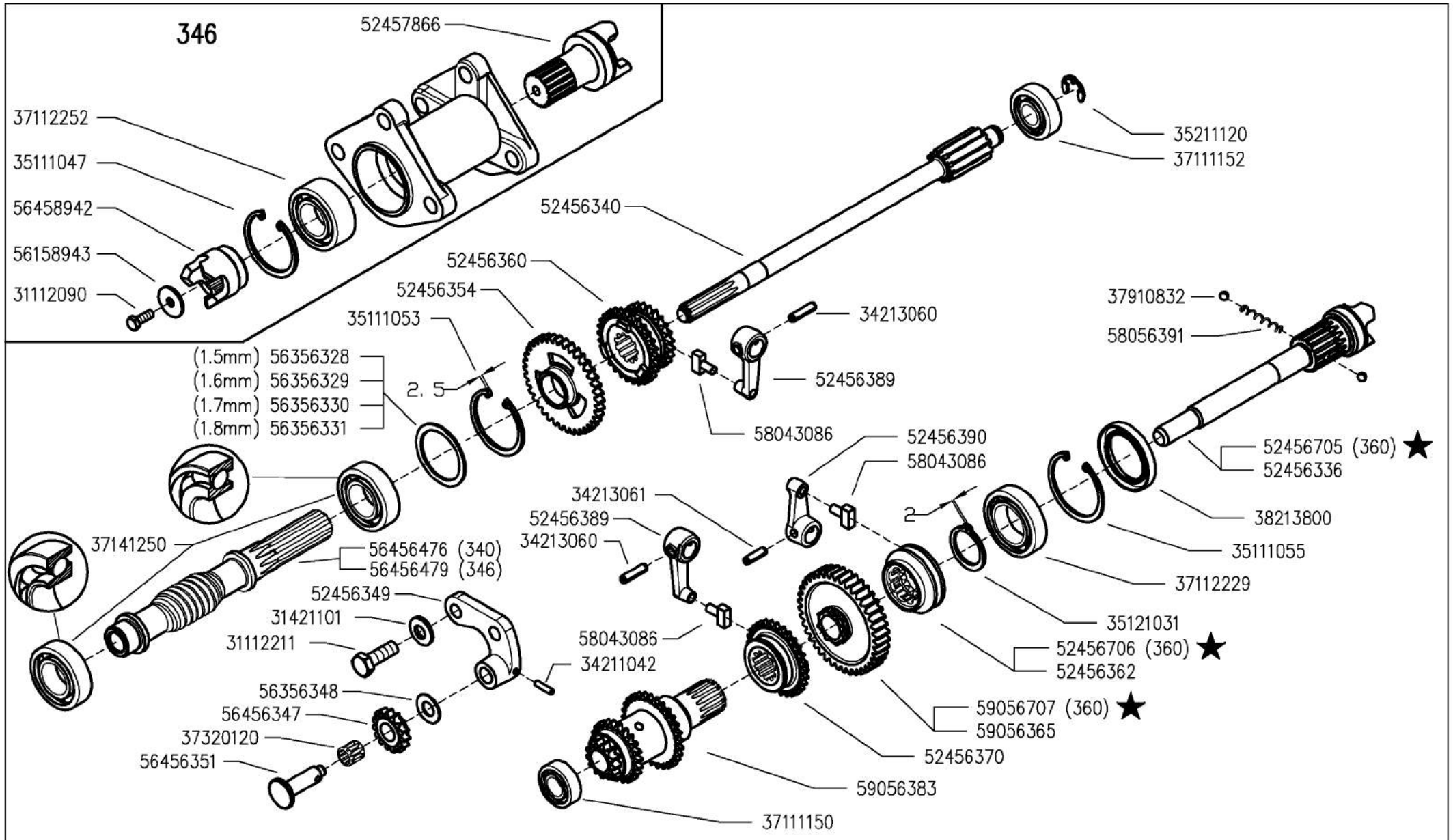

300 serie PS
PowerSafe®

GEARS
ENGRANAJES

INGRANAGGI CAMBIO
(340-346-360 ★)

ENGRANAGES
ZÄHNRÄDER

DALLA MACCHINA
DE LA MAQUINA
DE LA MACHINA
FROM THE MACHINE
AB DER MASCHINE



AGGIORNAMENTO
APLAZAMIENTO
MISE A JOUR
REVISION
ANPASSUNG

H03
1
11/2010

Rev.

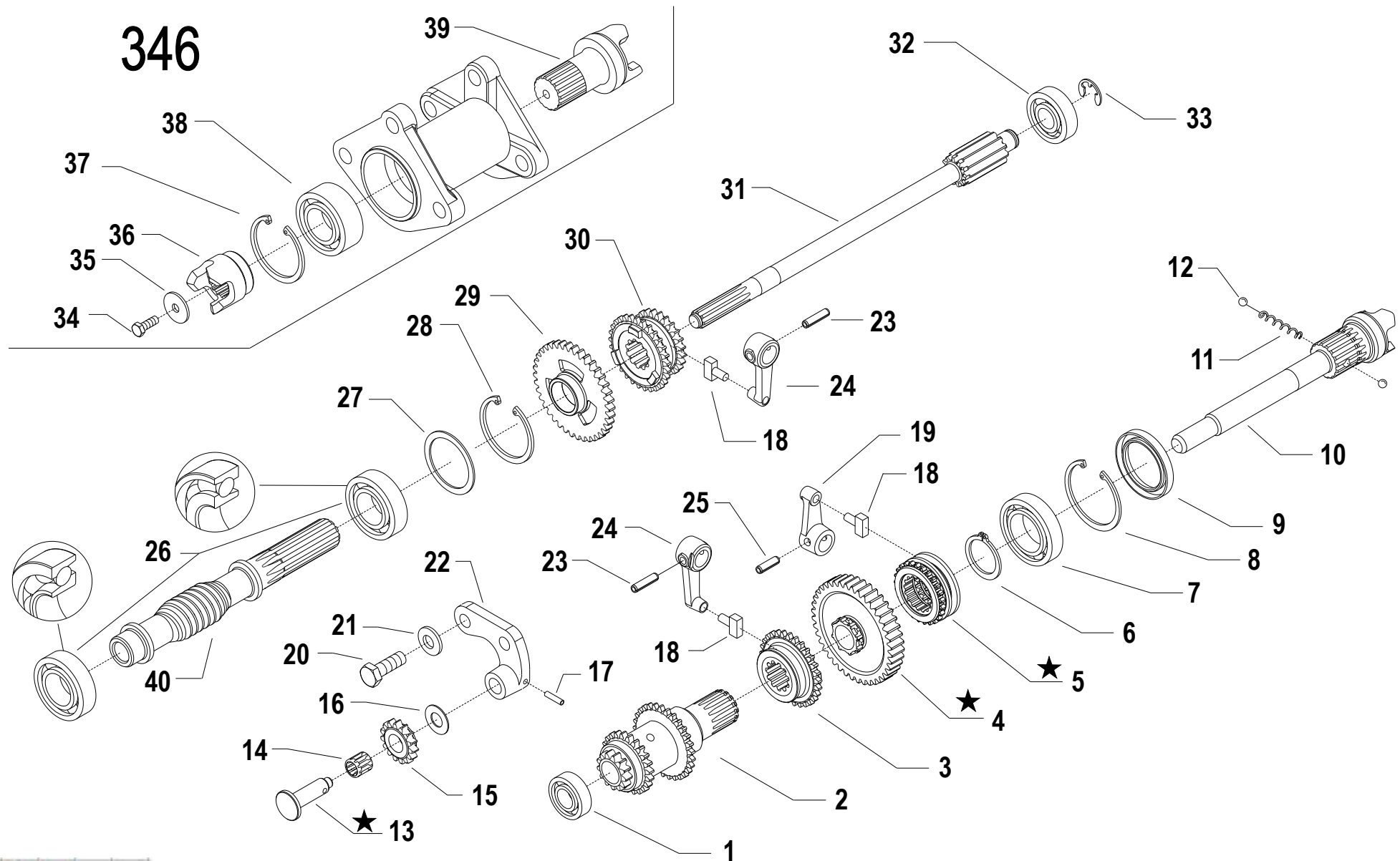

i = info - stop 2 sec. ★ = new part

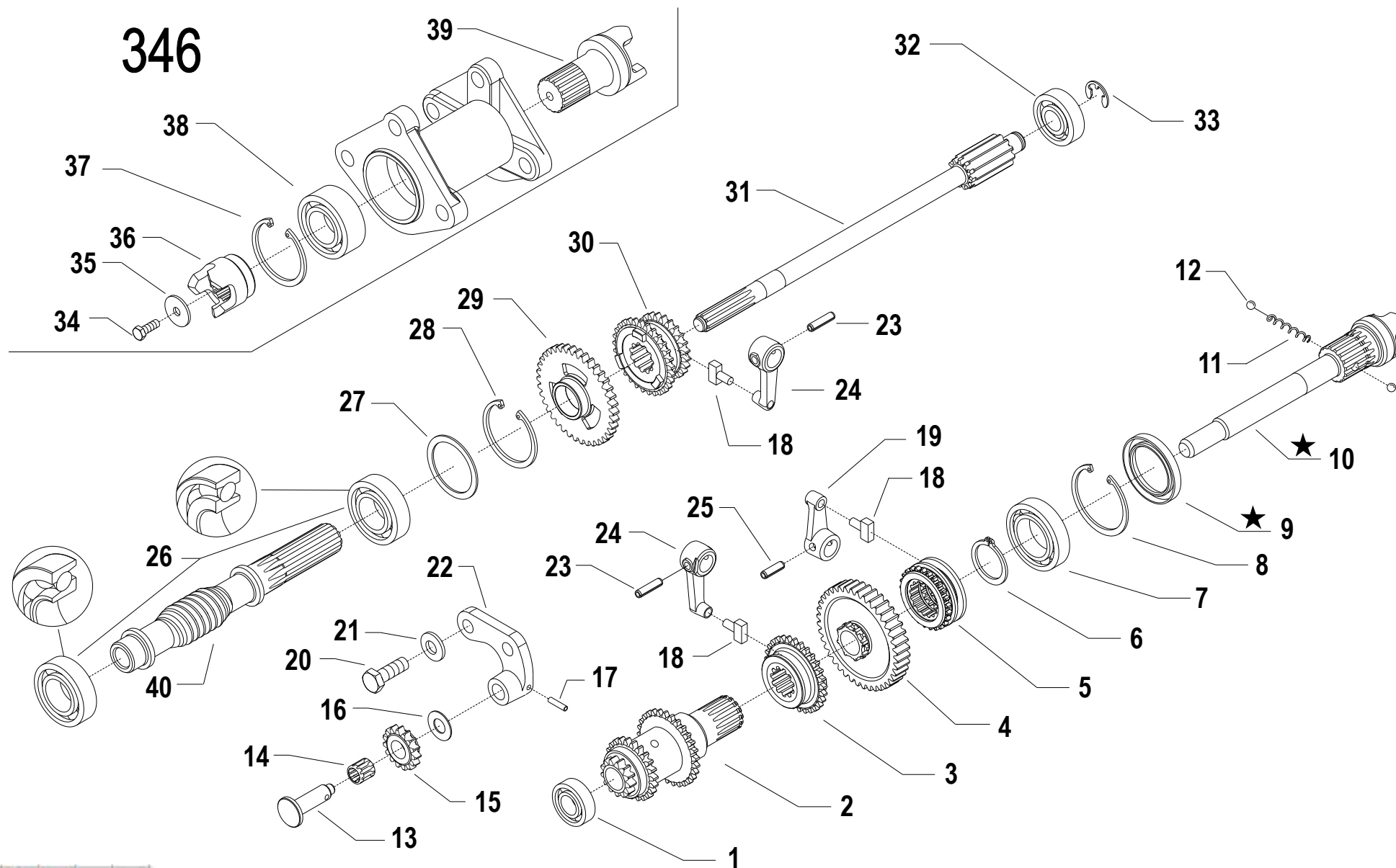

i = info - stop 2 sec. ★ = new part

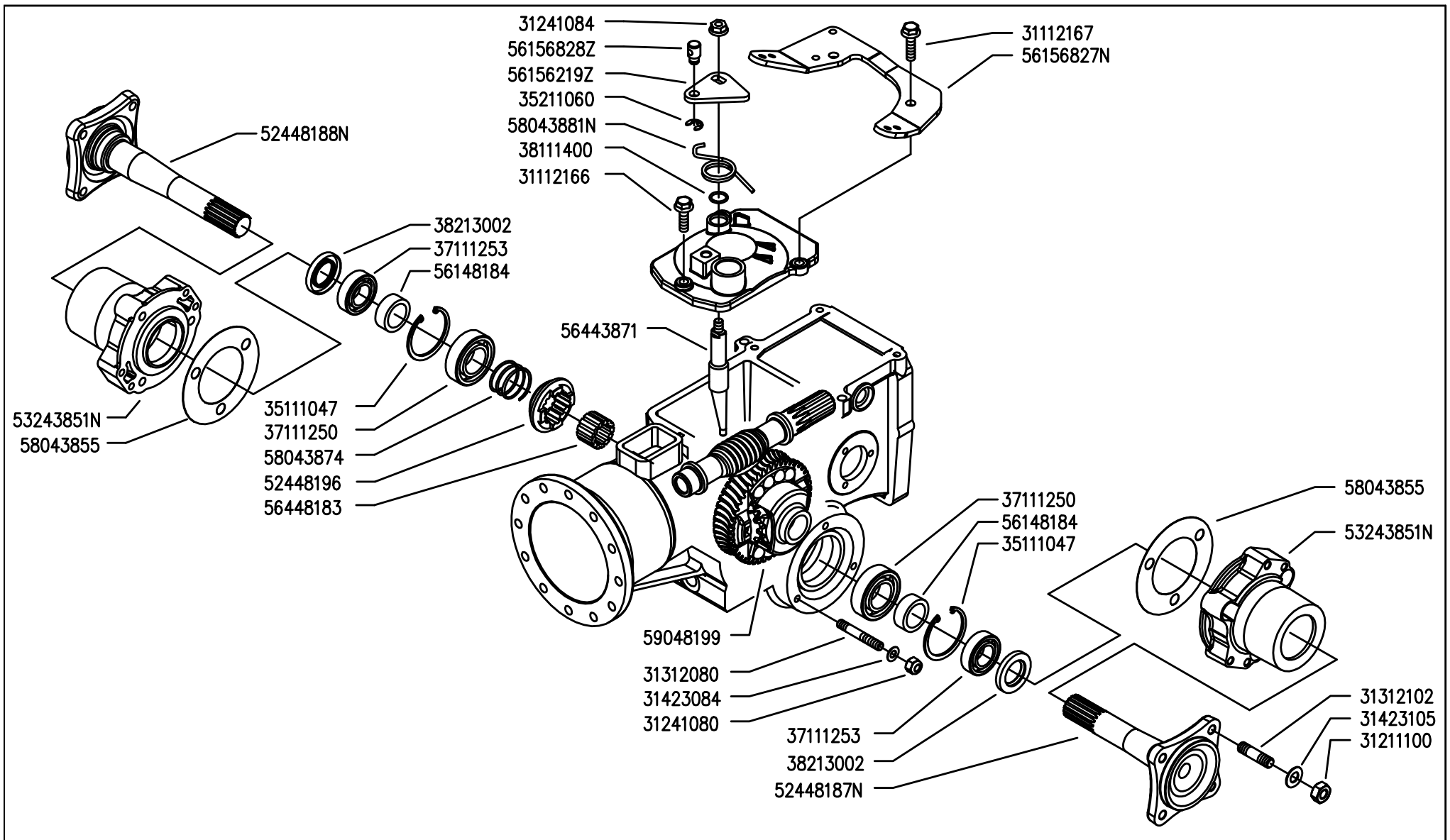

	300 serie PS PowerSafe®	WHEELS AXLE EJE RUEDAS	ASSE RUOTE (340)	ESSIEUS ROUES RÄDACHSE	DALLA MACCHINA DE LA MAQUINA DE LA MACHINA FROM THE MACHINE AB DER MASCHINE	<input type="text"/>	<input type="text"/>	<input type="text"/>	<input type="text"/>
						N.	103	0	05/2009

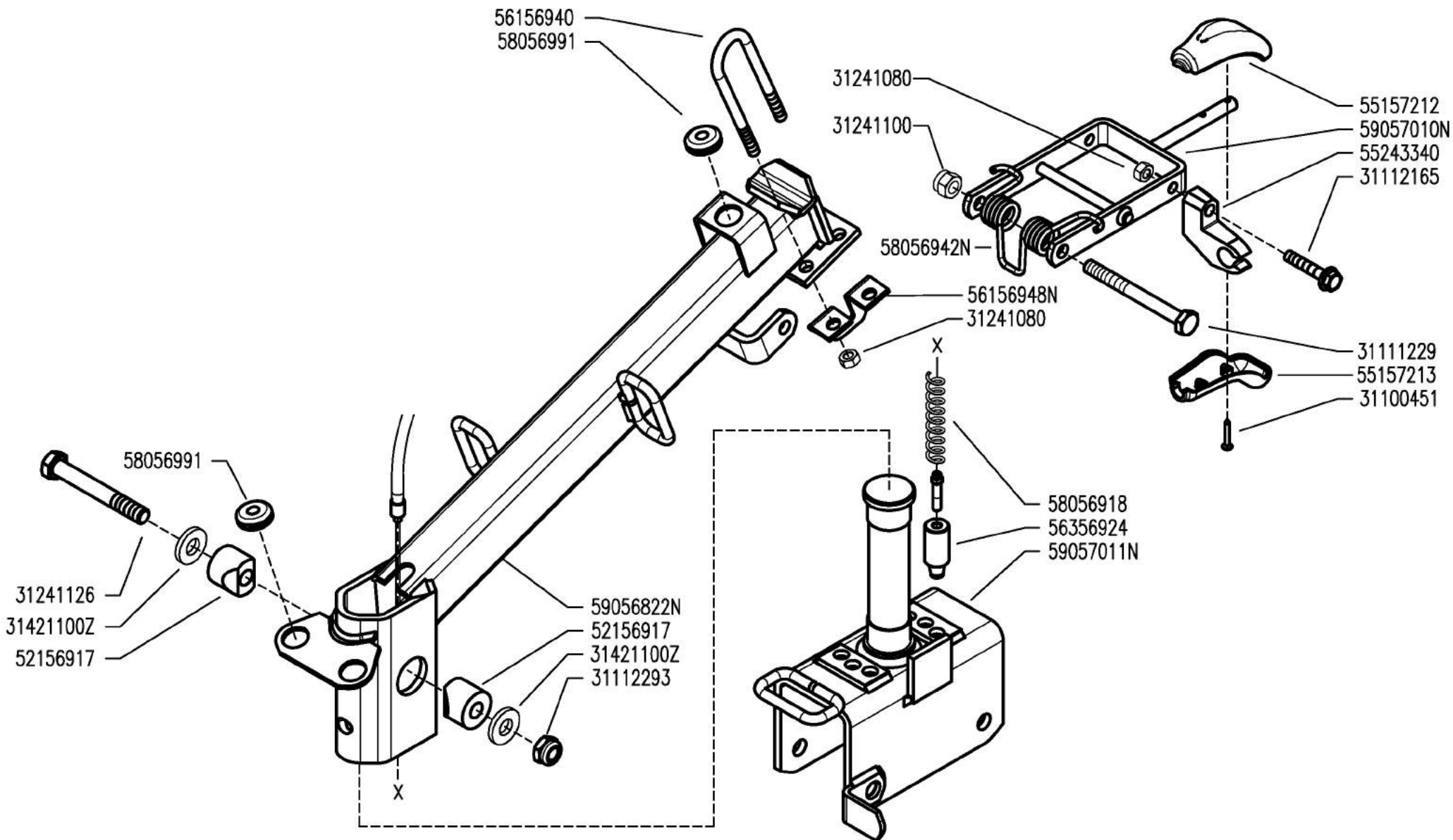

300 serie PS
PowerSafe®

STEERING COLUMN
COLUMNA

PIANTONE
(340-346)

PLANTON
LENKSÄULE

DALLA MACCHINA
DE LA MAQUINA
DE LA MACHINA
FROM THE MACHINE
AB DER MASCHINE

N.

J03 0

05/2009

Rev.

DITEBCS - Scala 1:4

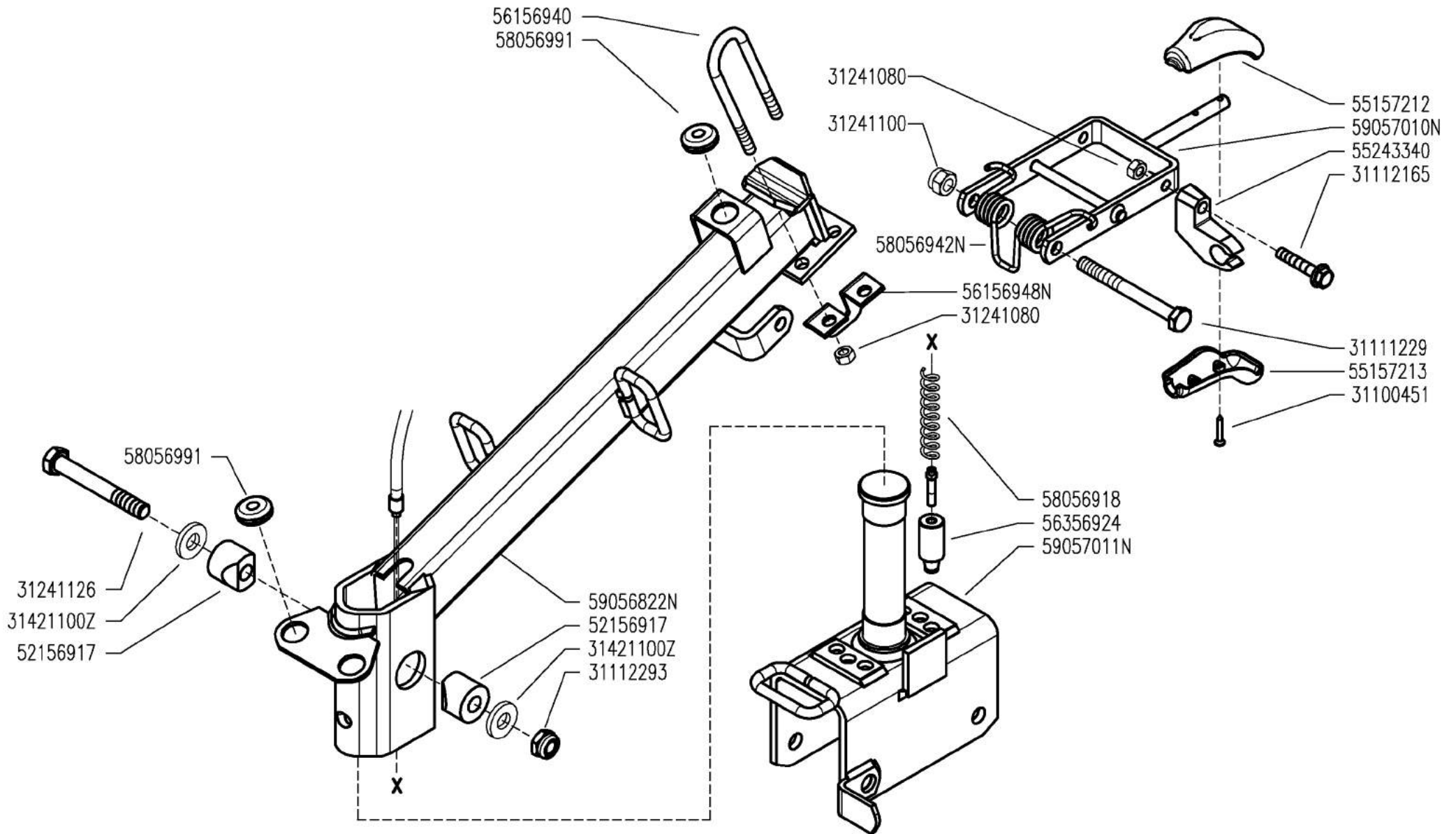

300 serie PS
PowerSafe®

STEERING COLUMN
COLUMNA

PIANTONE
(340-346-360 ★)

PLANTON
LENKSÄULE

DALLA MACCHINA
DE LA MACQUINA
DE LA MACHINA
FROM THE MACHINE
AB DER MASCHINE

★N.

AGGIORNAMENTO
APLAZAMIENTO
MISE A JOUR
REVISION
ANPASSUNG

J03

11/2010

Rev.

1

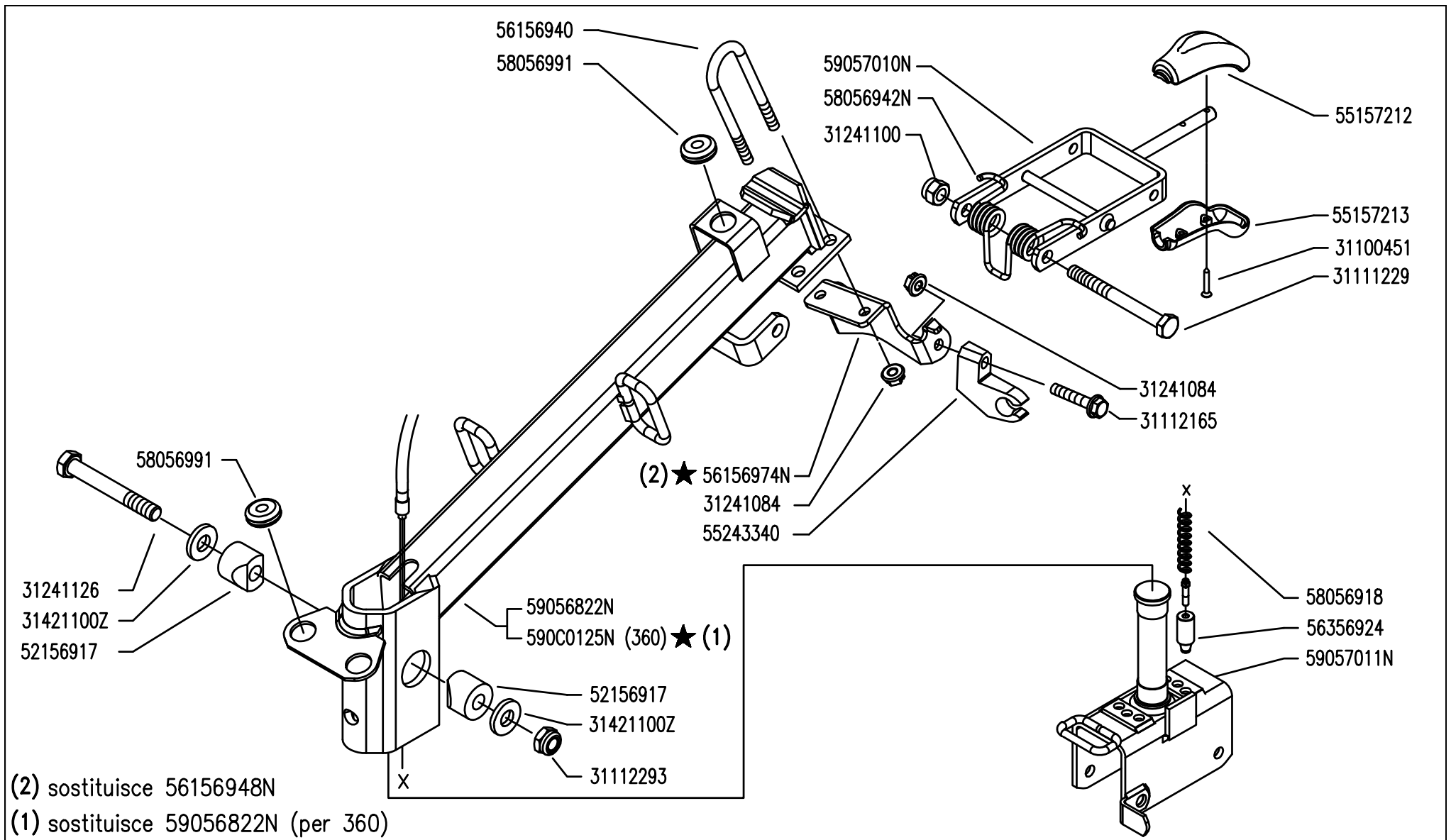

(2) sostituisce 56156948N
 (1) sostituisce 59056822N (per 360)

	300 serie PS PowerSafe®	STEERING COLUMN COLUMNA	PIANTONE (340-346-360)	PLANTON LENKSÄULE	DALLA MACCHINA DE LA MAQUINA DE LA MACHINE FROM THE MACHINE AB DER MASCHINE ★ N.	<input type="text"/>	J03	Rev. 2
						<input type="text"/>		
						901936	01/2012	

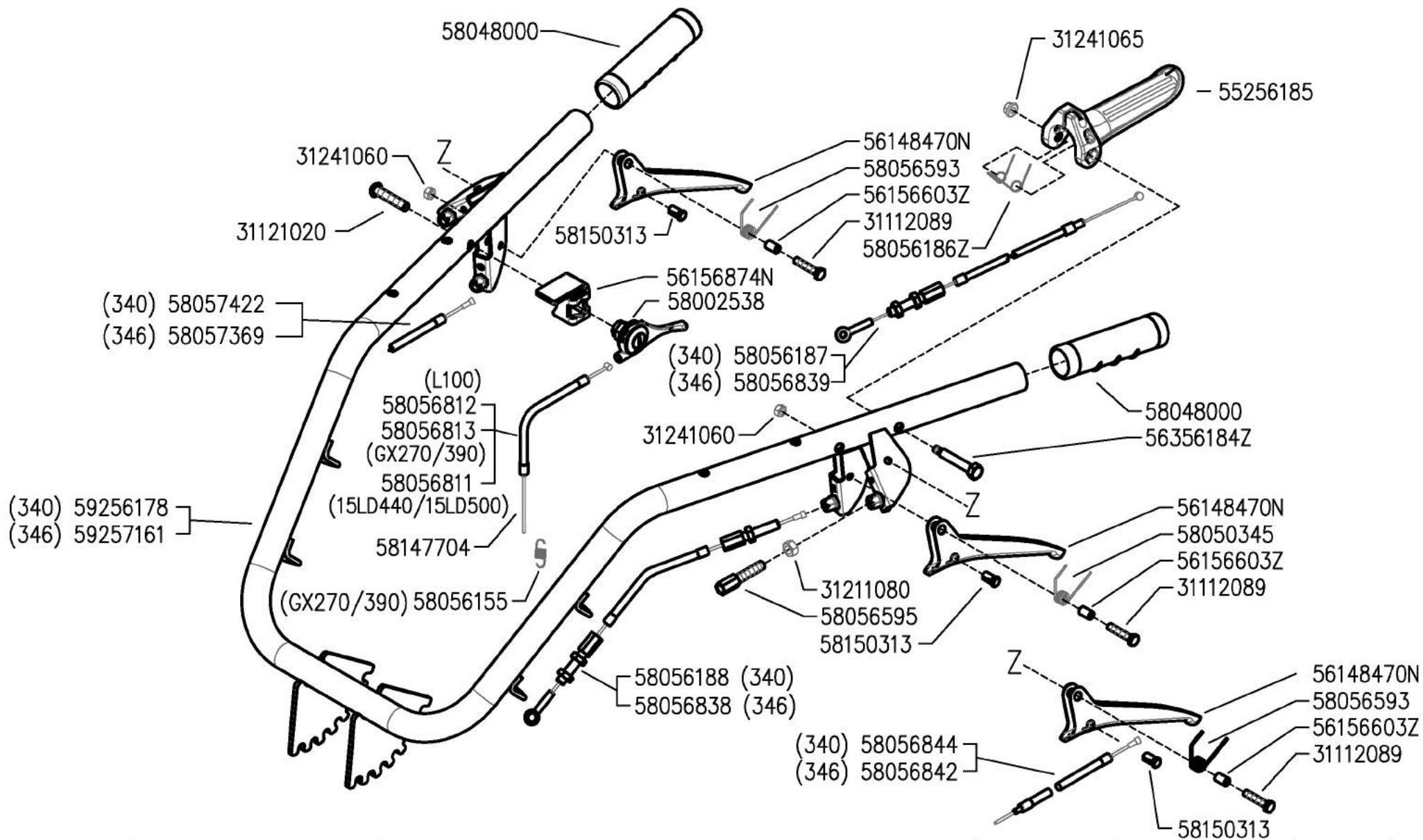

300 serie PS
PowerSafe®

HANDLEBAR
MANILLAR

MANUBRIO
(340-346)

MANCHERON
LINCHER

DALLA MACCHINA
DE LA MAQUINA
DE LA MAQUINA
FROM THE MACHINE
AB DER MASCHINE

N.

K03 0

05/2009

Rev.

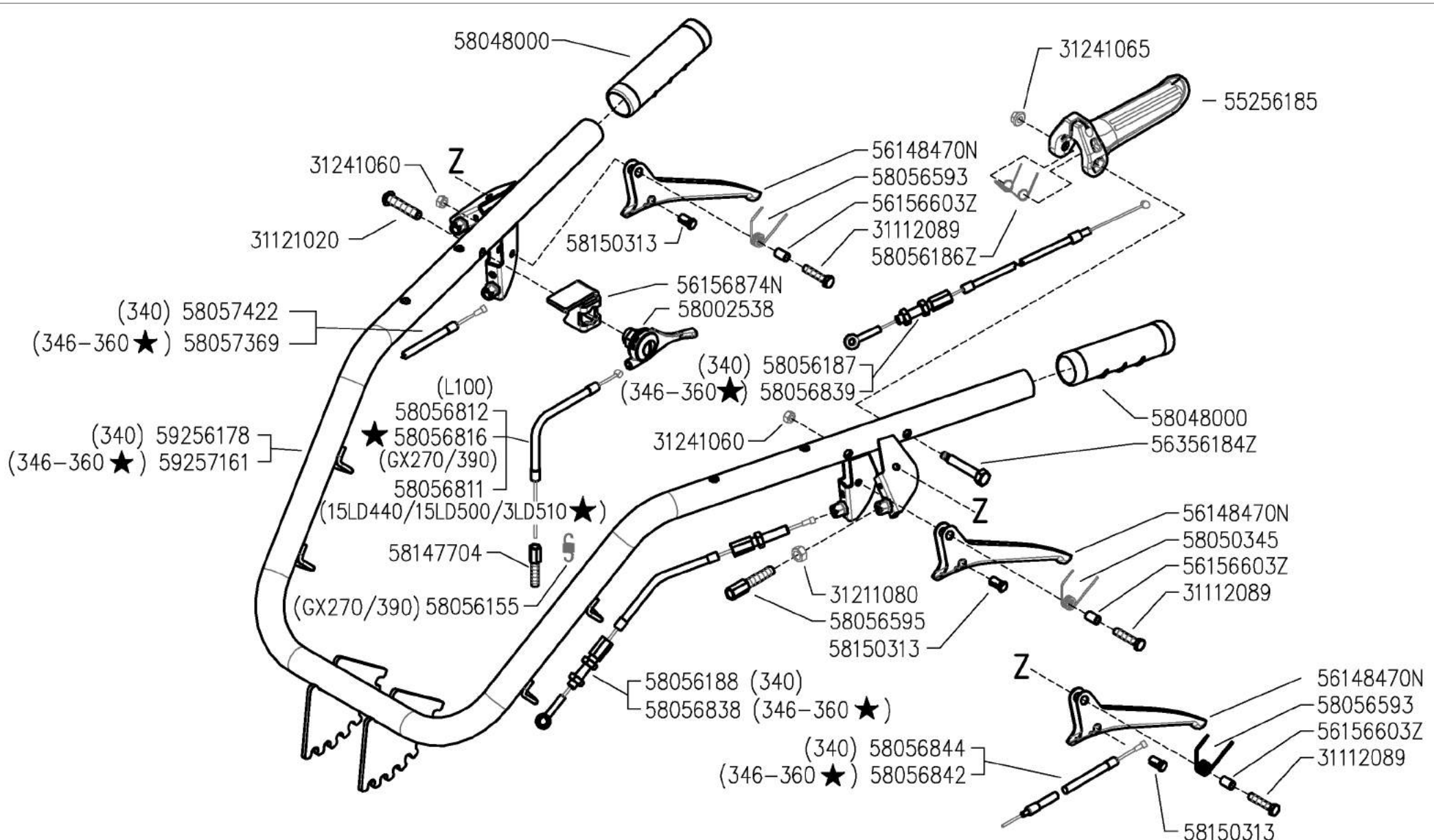

300 serie PS
PowerSafe®

HANDLEBAR
MANILLAR

MANUBRIO
(340-346-360 ★)

MANCHERON
LINCHER

DALLA MACCHINA
DE LA MAQUINA
DE LA MACHINA
FROM THE MACHINE
AB DER MASCHINE

★ N.

AGGIORNAMENTO
APLAZAMIENTO
MISE A JOUR
REVISION
ANPASSUNG

K03 1

11/2010

Rev.

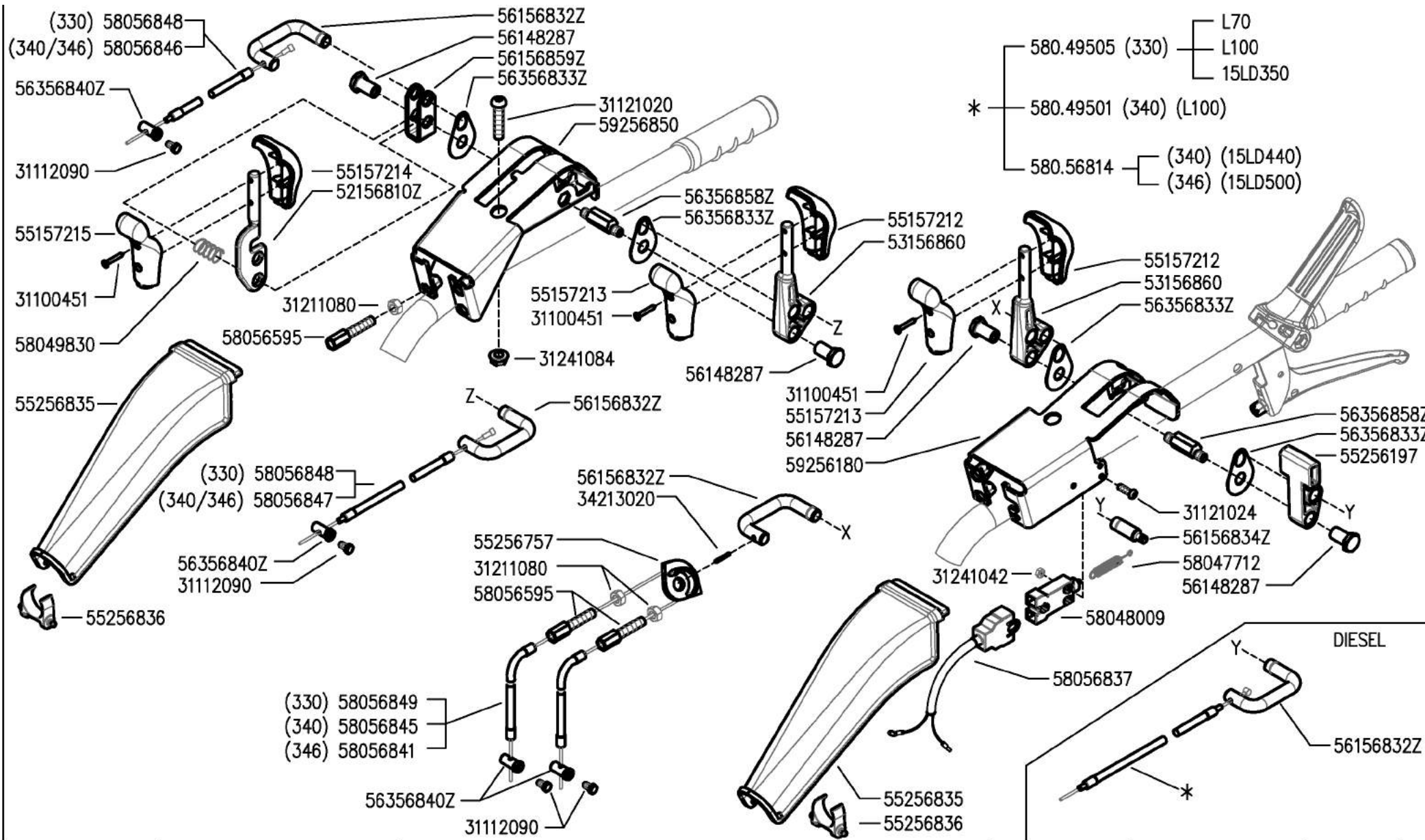

300 serie PS
PowerSafe®

HANDLEBAR CONTROLS
CONTROLES EN EL MANILLAR

COMANDI SUL MANUBRIO
(330-340-346)

CONTROLES SUR LE MANCHERON
KONTROLLEN AM LINCHER

DALLA MACCHINA
DE LA MAQUINA
DE LA MAQUINA
FROM THE MACHINE
AB DER MASCHINE

N.

L03 0

05/2009

Rev.

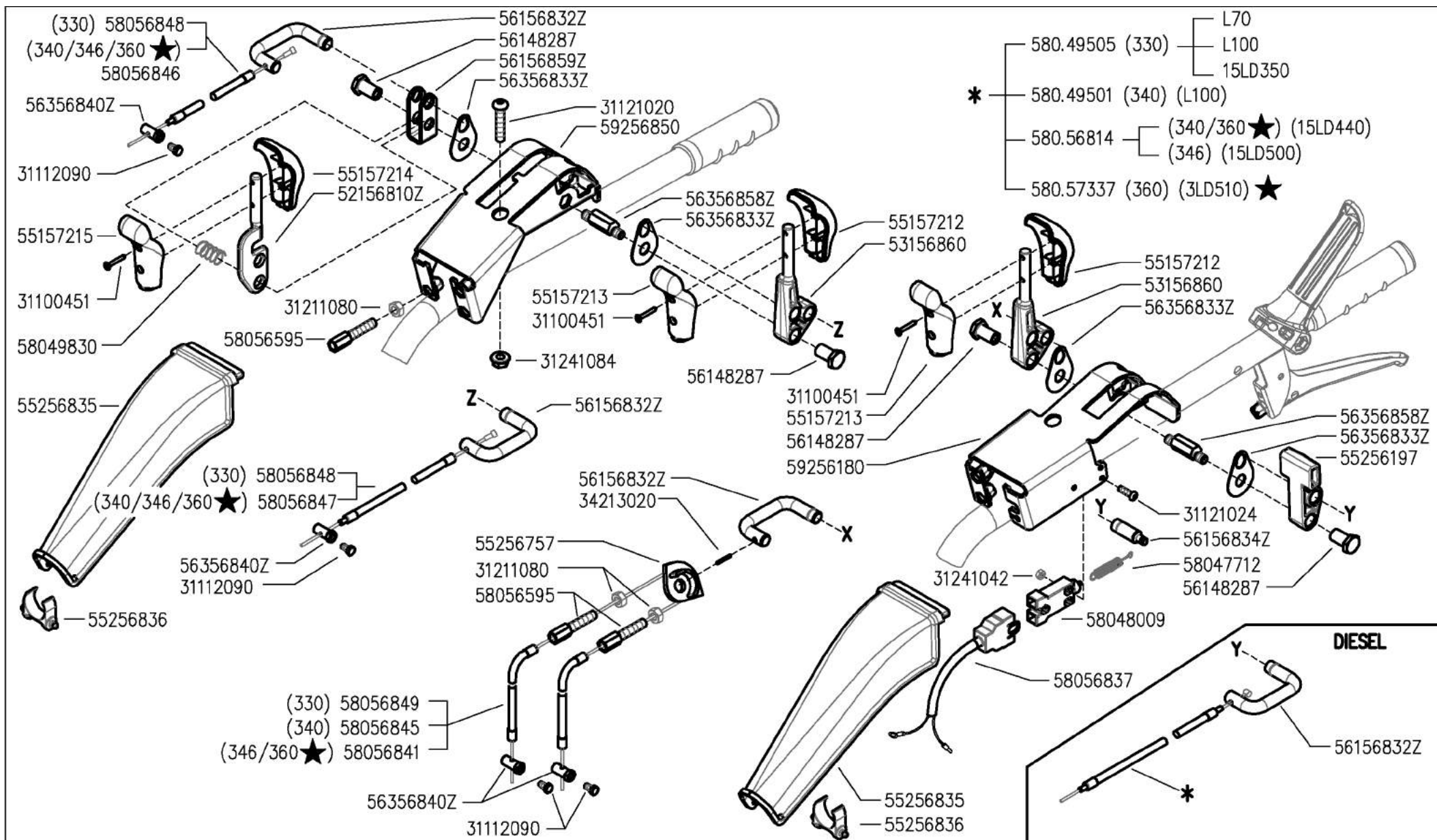

300 serie PS
PowerSafe®

HANDLEBAR CONTROLS

CONTROLES EN EL MANILLAR

COMANDI SUL MANUBRIO

(330-340-346-360 ★)

CONTROLES SUR LE MANCHERON

KONTROLLEN AM LINCHER

DALLA MACCHINA
DE LA MAQUINA
DE LA MAQUINA
FROM THE MACHINE
AB DER MASCHINE

★ N.

AGGIORNAMENTO

APLAZAMIENTO

MISE A JOUR

REVISION

ANPASSUNG

L03

11/2010

Rev.

1

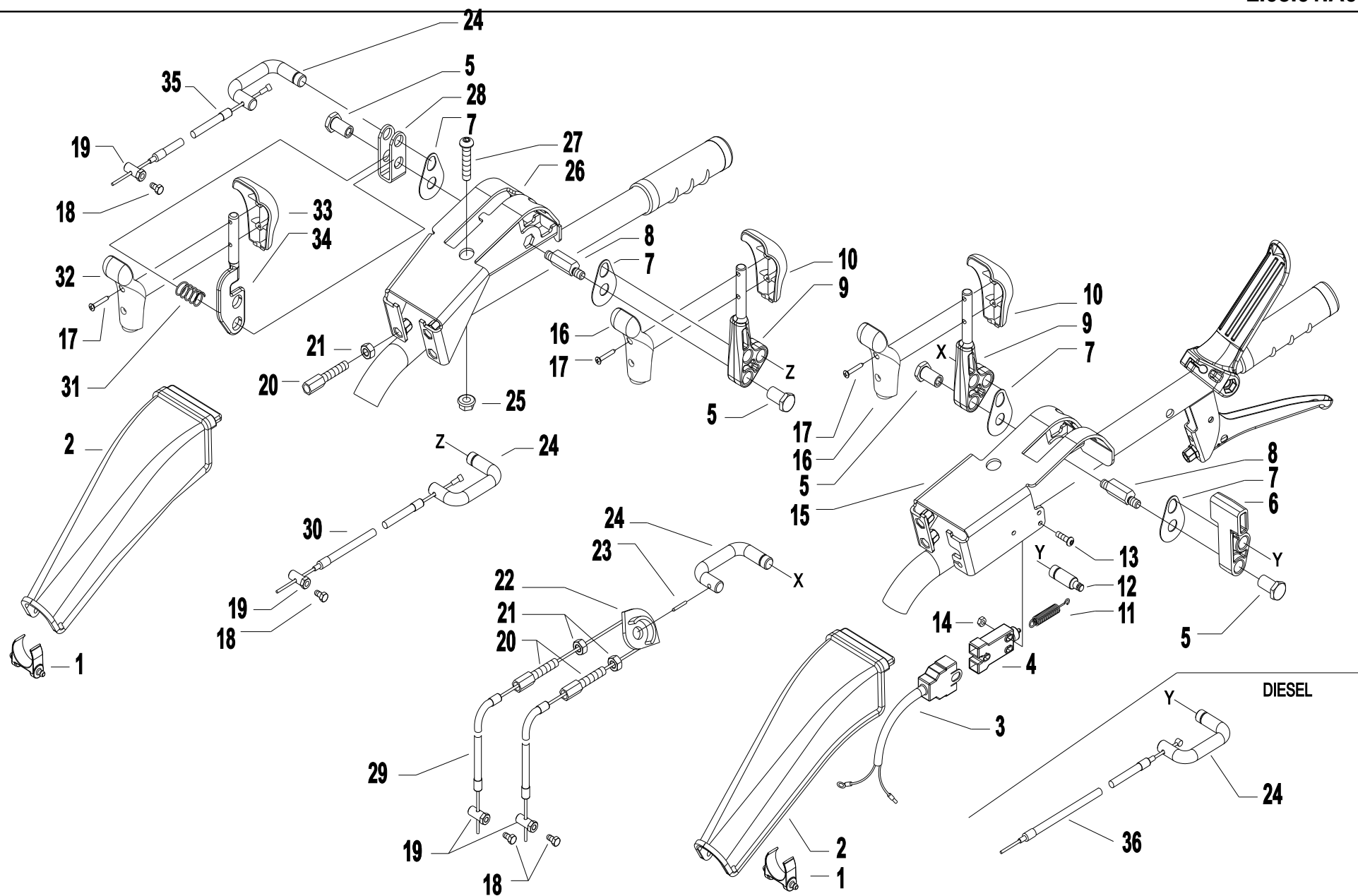

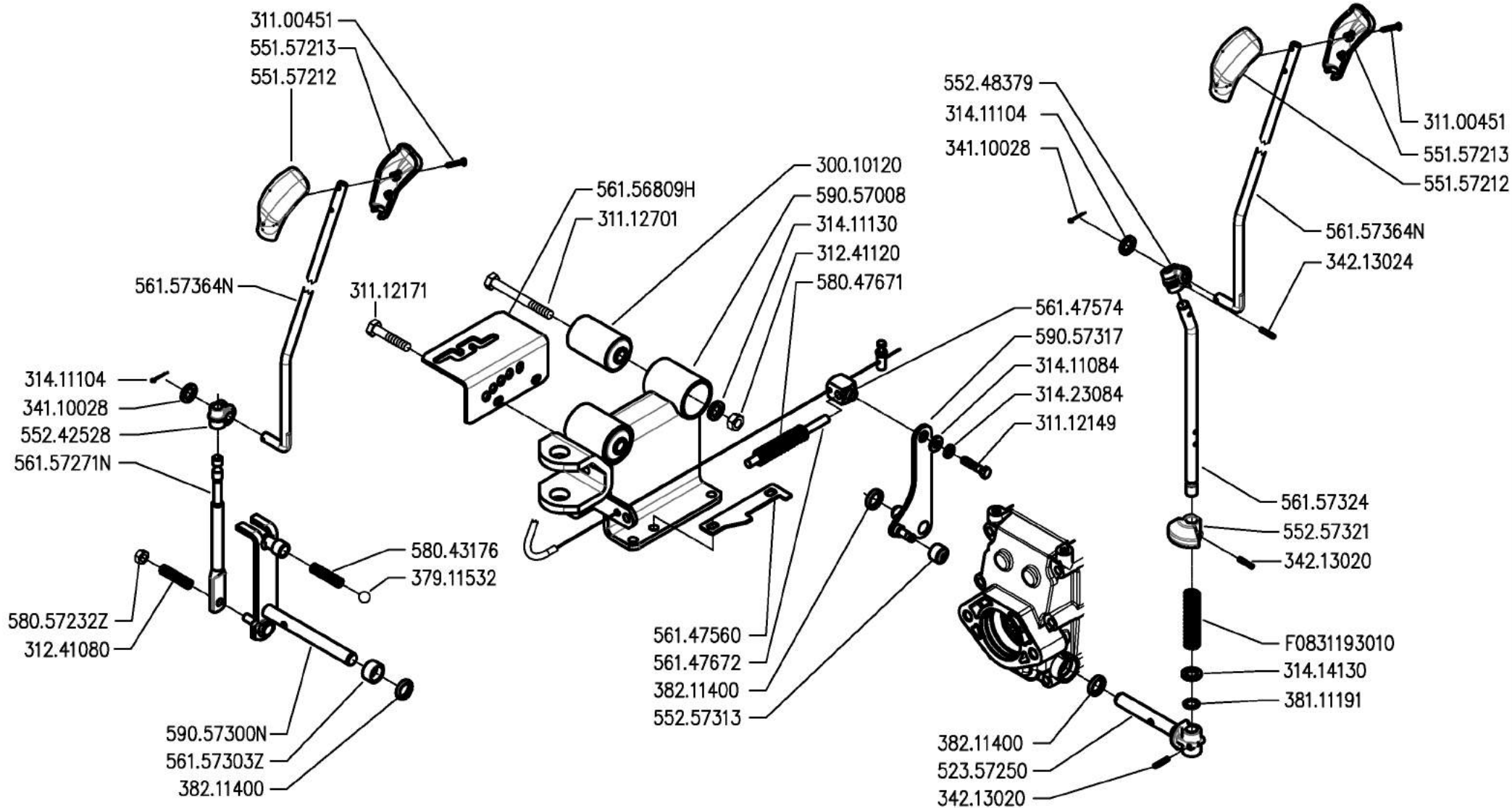

FERRARI

300 serie PS
PowerSafe®

CONTROLS
MANDOS

COMANDI
(340-346)

COMMANDES
ANTRIEBE

DALLA MACCHINA
DE LA MAQUINA
DE LA MAQUINA
FROM THE MACHINE
AB DER MASCHINE

N.

M03 0

05/2009

Rev.

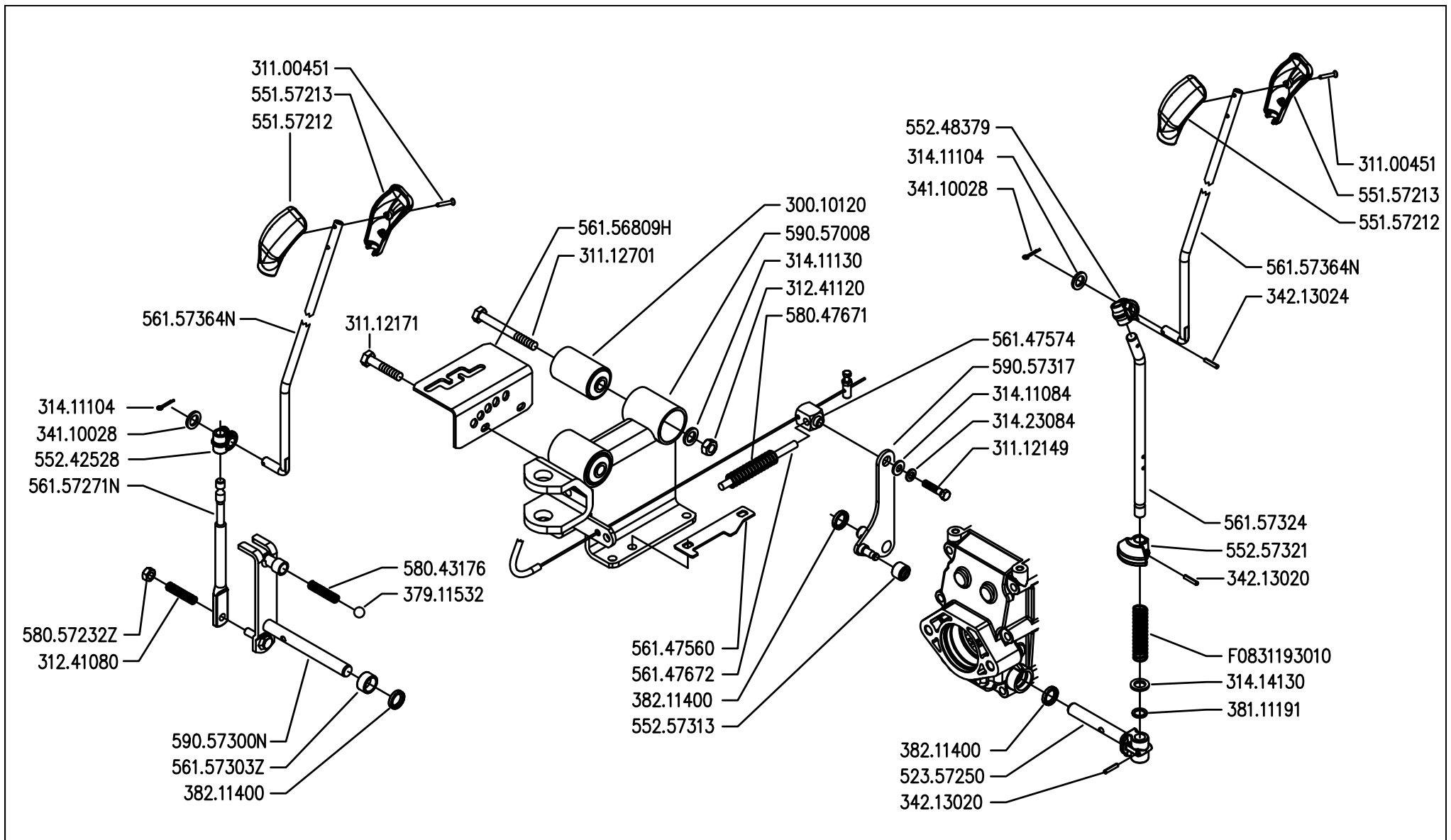

300 serie PS
PowerSafe®

CONTROLS
MANDOS

COMANDI
(340-346-360 ★)

COMMANDES
ANTRIEBE

DALLA MACCHINA
DE LA MAQUINA
DE LA MACHINA
FROM THE MACHINE
AB DER MASCHINE



AGGIORNAMENTO
APLAZAMIENTO
MISE A JOUR
REVISION
ANPASSUNG

M03 1

11/2010

Rev.

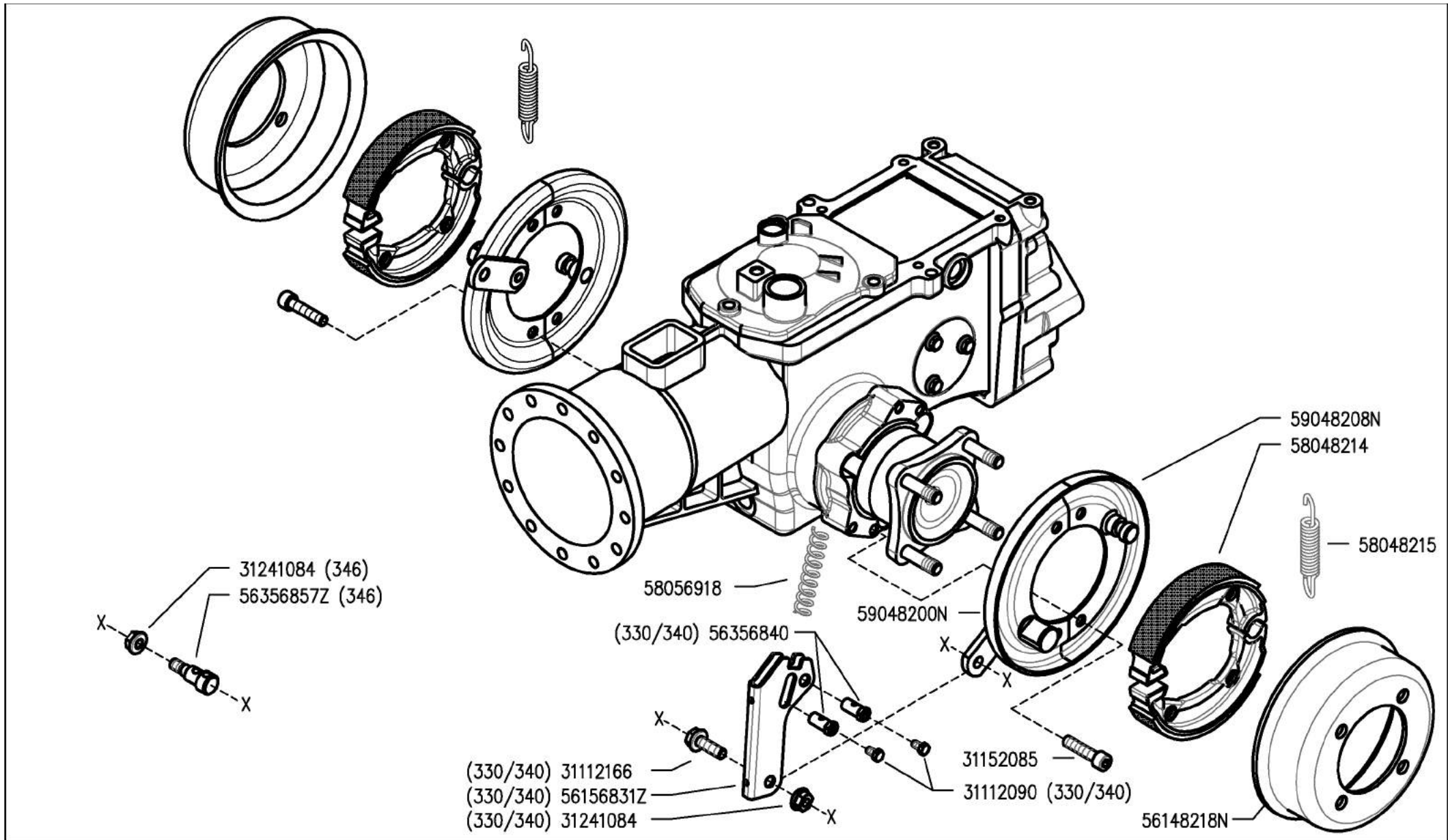

300 serie PS
PowerSafe®

BRAKES
FRENOS

FRENI
(330-340-346)

FREINS
BREMSEN

DALLA MACCHINA
DE LA MAQUINA
DE LA MACHINA
FROM THE MACHINE
AB DER MASCHINE

N.

N02 0

05/2009

Rev.

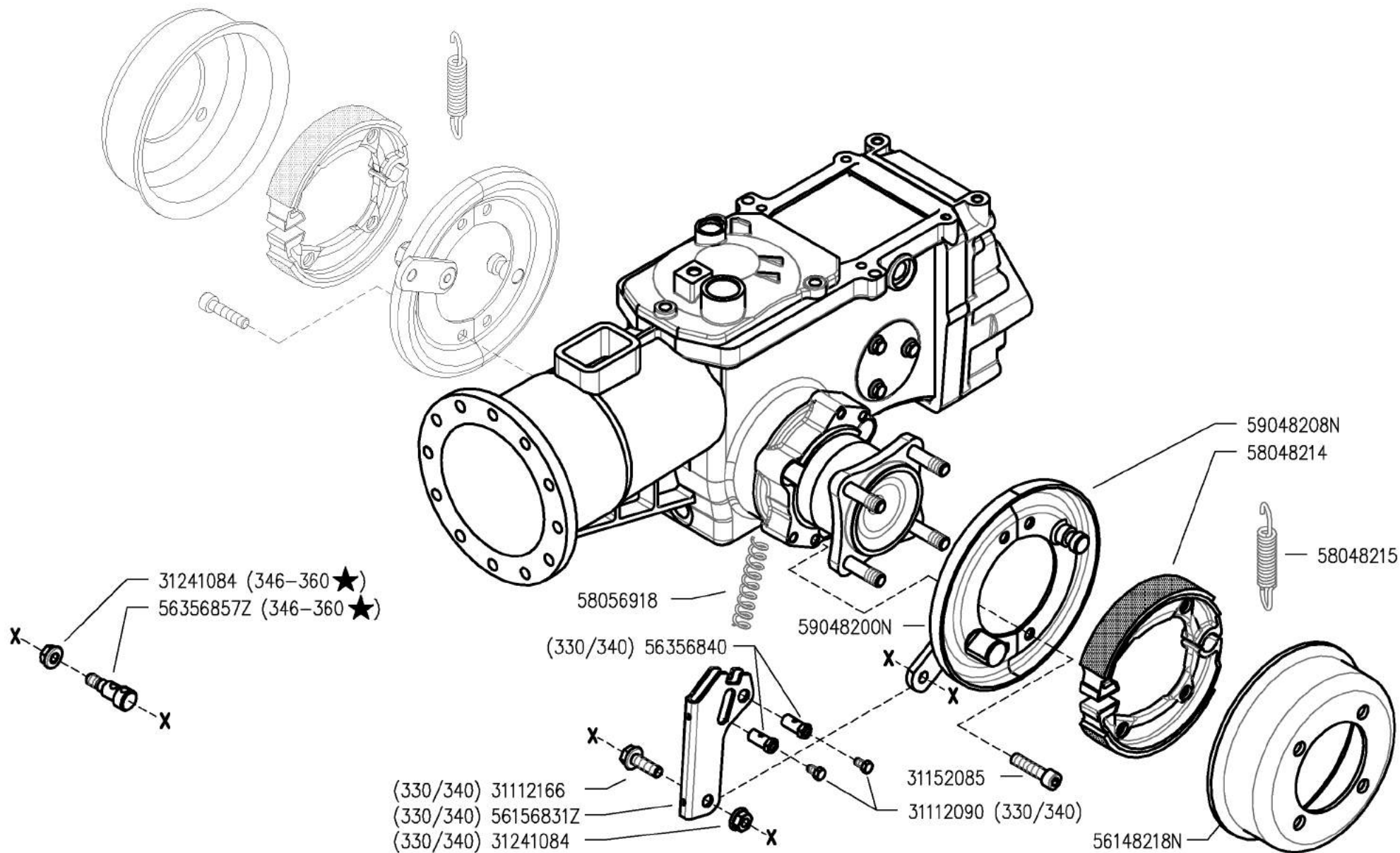

300 serie PS
PowerSafe®

BRAKES
FRENOS

FRENI
(330-340-346-360 ★)

FREINS
BREMSEN

DALLA MACCHINA
DE LA MAQUINA
DE LA MACHINA
FROM THE MACHINE
AB DER MASCHINE

★ N.

AGGIORNAMENTO
APLAZAMIENTO
MISE A JOUR
REVISION
ANPASSUNG

N02 1

11/2010

Rev.

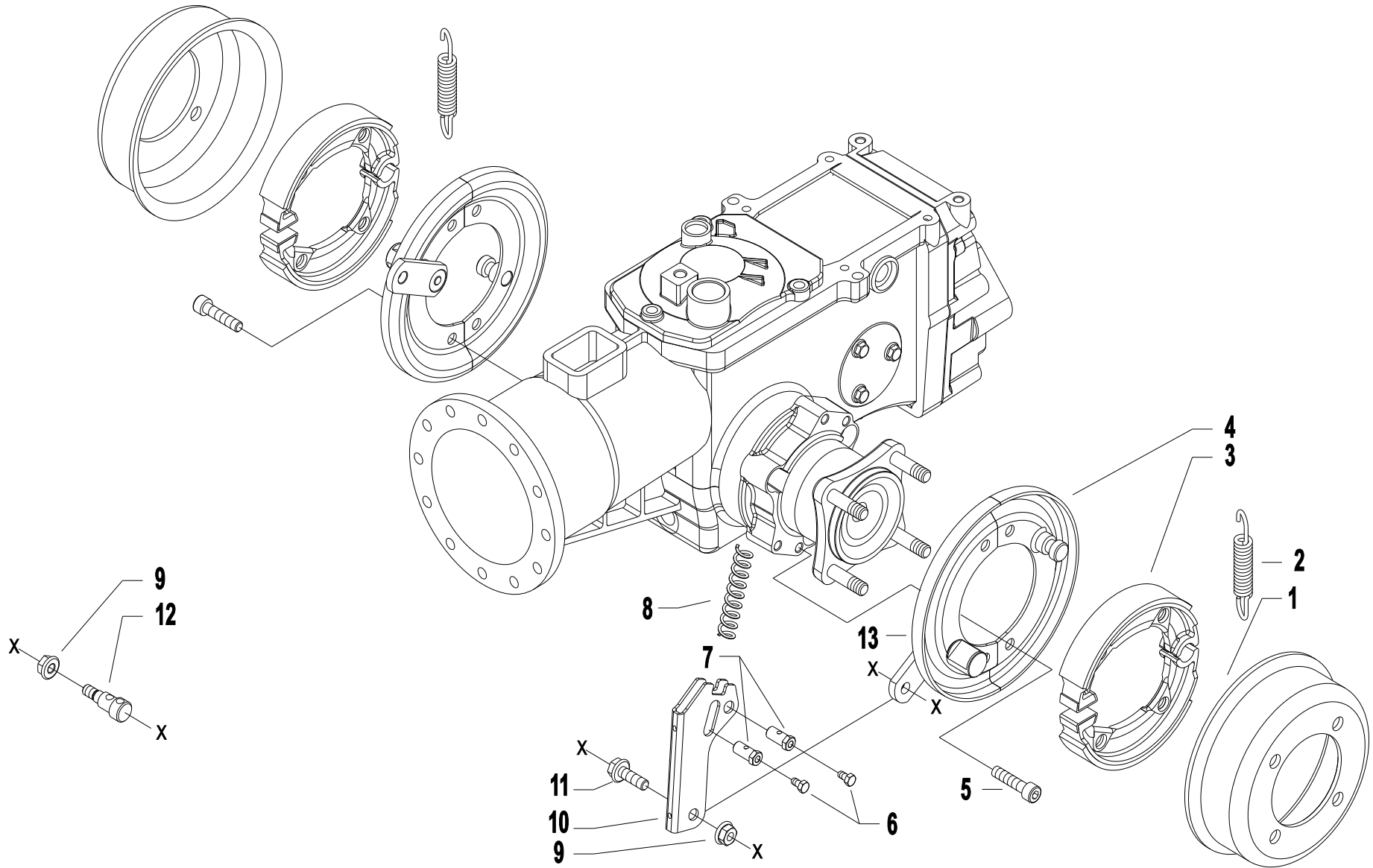

	A	B	C	D
4.00 - 8"	39114008	39414008	58052326	92480719 (kg.11)
4.0 - 10"	39114010	39414010	58052327	92480720 (kg.15)
4.0 - 10"	39114010	39414010	58052288 (FIX)	-
5.0 - 10"	39115010	39415010	58052327	92480720 (kg.15)
5.0 - 10"	39115010	39415010	58052288 (FIX)	-
5.00 - 12"	39115012	39415012	58052328	92480721 (kg.34)
6.5/80 - 12"	39116018	39416018	58052328	92480721 (kg.34)
6.5/80 - 15"	39116020	39416020	58052332	92480721 (kg.34)

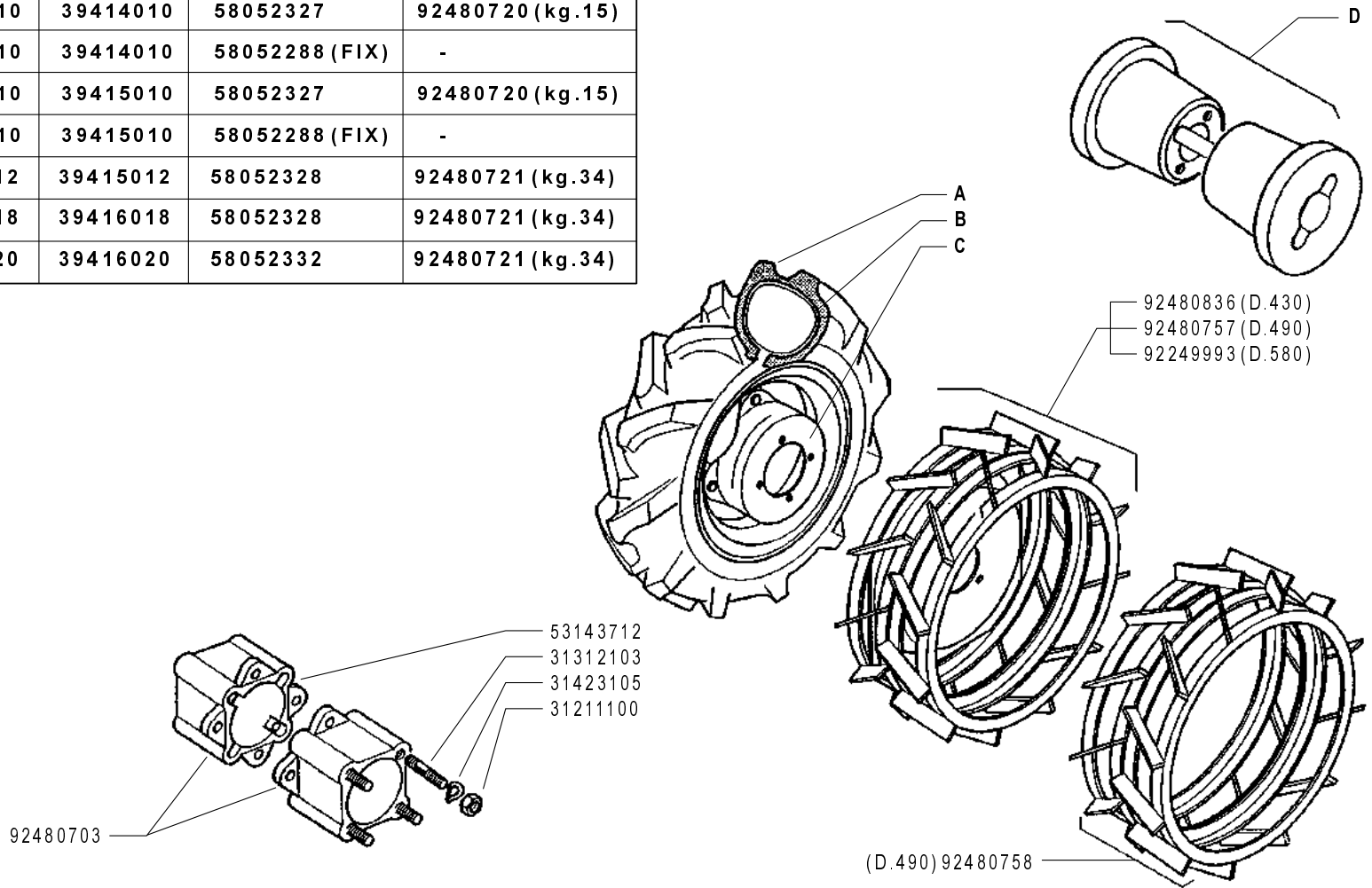

FERRARI

300 serie **PS**
PowerSafe®

RUOTE

WHEELS
RUEDAS

ROUES
RÄDER

DALLA MACCHINA
FROM THE MACHINE
DE LA MACHINE
DE LA MAQUINA
AB DER MASCHINE

N.

P01 0

05/2009

Rev.

ZENNE

	A	B	C	D
4.00 - 8"	39114008	39414008	58043250 ★	92480719 (kg.11)
4.0 - 10"	39114010	39415010 ★	58048330 ★	92480720 (kg.15)
5.0 - 10"	39115010	39415010	58048330 ★	92480720 (kg.15)
5.00 - 12"	39115012	39415012	58044804 ★	92480721 (kg.34)
6.5/80 - 12"	39116018	39416018	58044804 ★	92480721 (kg.34)
6.5/80 - 15"	39116020	39416020	58042746 ★	92480721 (kg.34)

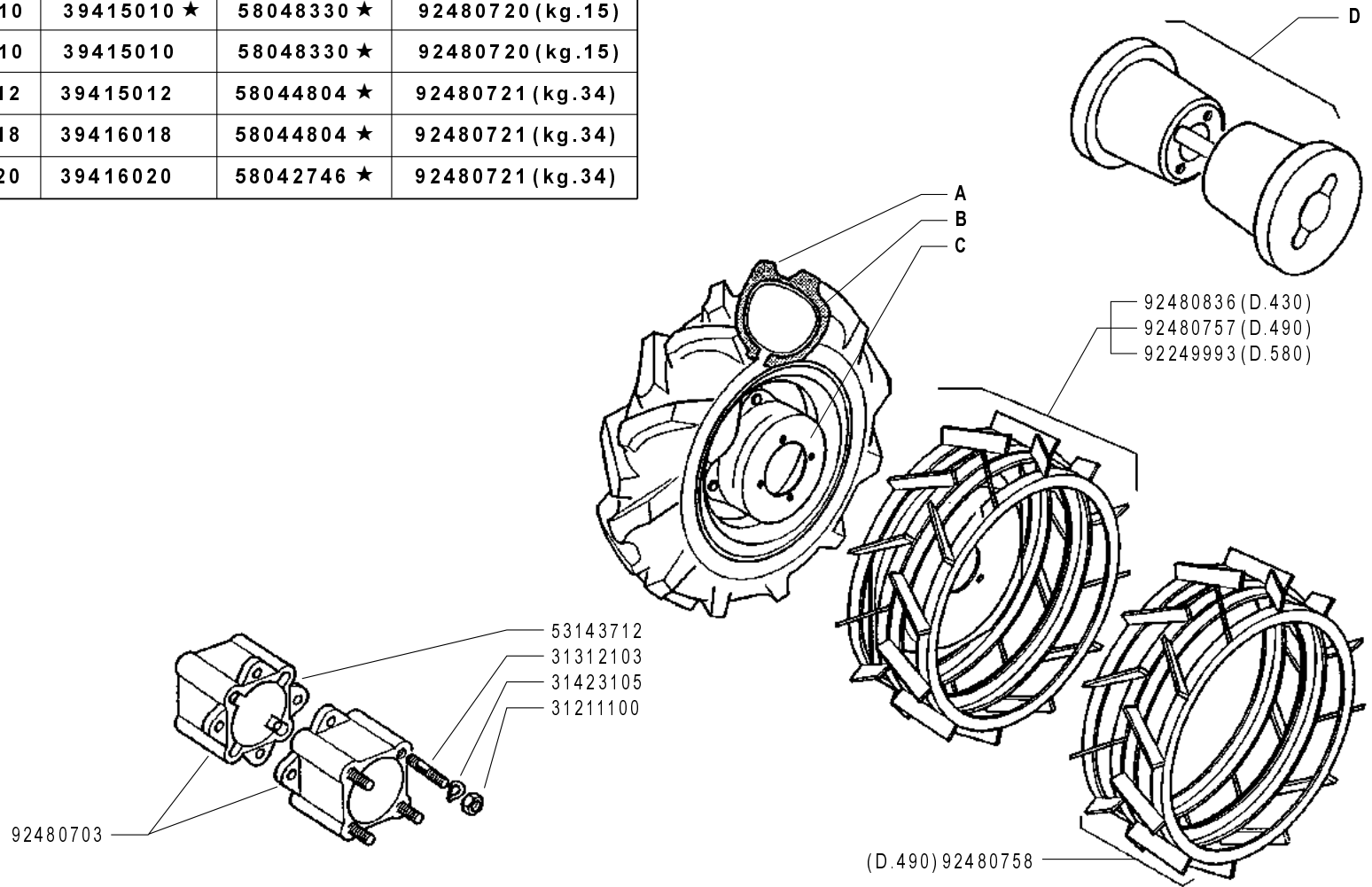

FERRARI

300 serie **PS**
PowerSafe®

WHEELS
RUEDAS

RUOTE

ROUES
RÄDER

DALLA MACCHINA
FROM THE MACHINE
DE LA MACHINE
DE LA MAQUINA
AB DER MASCHINE

★ N.

AGGIORNAMENTO
REVISION
MISE A JOUR
APLAZAMIENTO
ANPASSUNG

P01 1

11/2010

Rev.

ZENNE

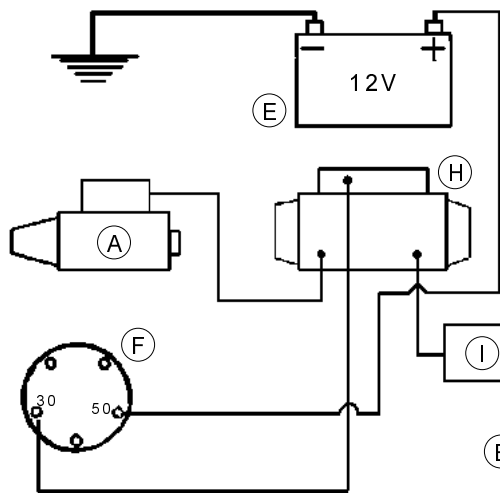

HONDA

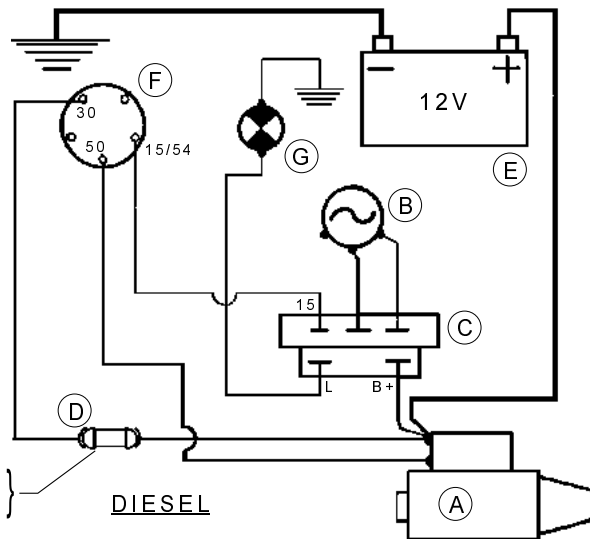

(Yanmar) 15A
(Lombardini) 25A

DIESEL

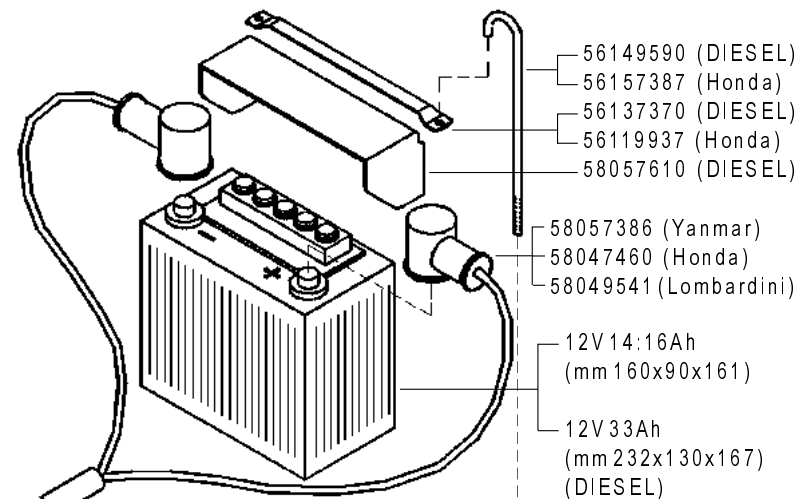

- 56149590 (DIESEL)
- 56157387 (Honda)
- 56137370 (DIESEL)
- 56119937 (Honda)
- 58057610 (DIESEL)
- 58057386 (Yanmar)
- 58047460 (Honda)
- 58049541 (Lombardini)
- 12V 14:16Ah
(mm 160x90x161)
- 12V 33Ah
(mm 232x130x167)
(DIESEL)

A	B	C	D
MOTORINO D'AVVIAMENTO STARTER DÉMARREUR MOT. DEARRANQUE ANLASSMOTOR	GENERATORE GENERATOR GÉNÉRATEUR GENERADOR GENERATOR	REGOLATORE REGULATOR RÉGULATEUR REGULADOR REGLER	FUSIBILI FUSES FUSIBLES FUSIBLES SCHMELZSICHERUNGEN

E	F	G	H	I
BATTERIA BATTERY BATTERIE BATERIA BATERIE	INTERRUTTORE SWITCH INTERRUPTEUR INTERRUPTOR SCHALTER	SPIA CARICA BATTERIA BATTERY LONG WARN. LIGHT TEMOIN CHARG. BATTERIE LUZ CARGA BATERIA BATTERIELADUNG KTRL. LAMPE	SOLENOIDE SOLENOID SOLÉNOÏDE SOLENOIDE SOLENOID	DIODO DIODE DIODE DIODE DIODE

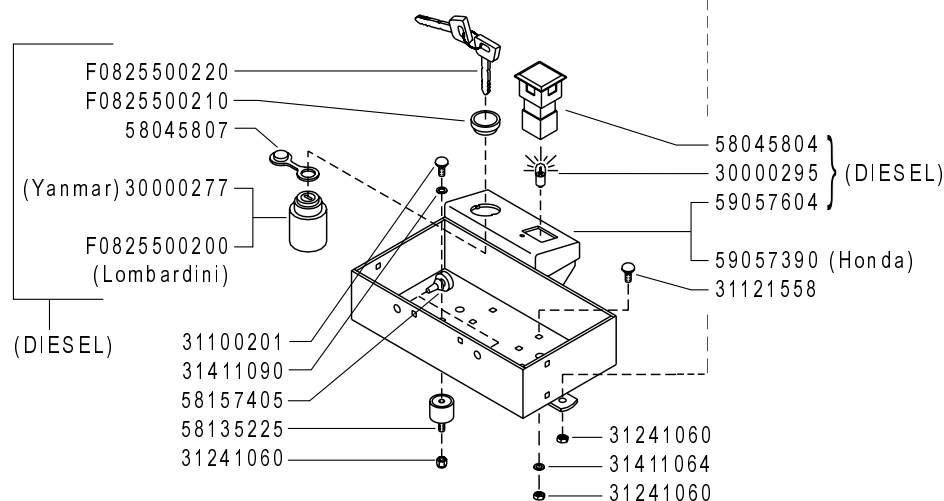

- F0825500220
- F0825500210
- 58045807
- (Yanmar) 30000277
- F0825500200
(Lombardini)
- (DIESEL)
- 58045804
- 30000295
- 59057604
- 59057390 (Honda)
- 31121558
- 31100201
- 31411090
- 58157405
- 58135225
- 31241060
- 31241060
- 31411064
- 31241060

FERRARI

300 serie **PS**
PowerSafe®

AVVIAMENTO ELETTRICO

ELECTRIC STARTER
ARRANQUE ELECTRICO

DÉMARRAGE ELECTRIQUE
ELEKTROSTART

DALLA MACCHINA
FROM THE MACHINE
DE LA MACHINE
DE LA MAQUINA
AB DER MASCHINE

N.

Q01 0

05/2009

Rev.

ZENNE

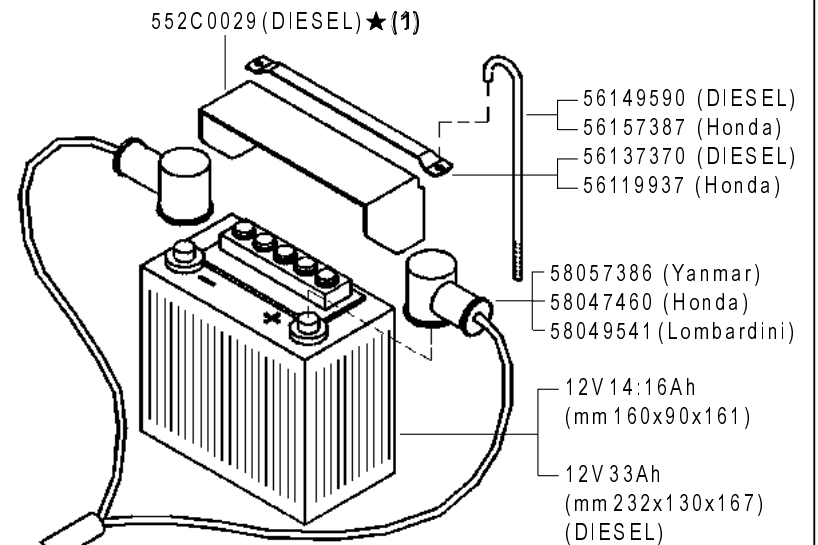
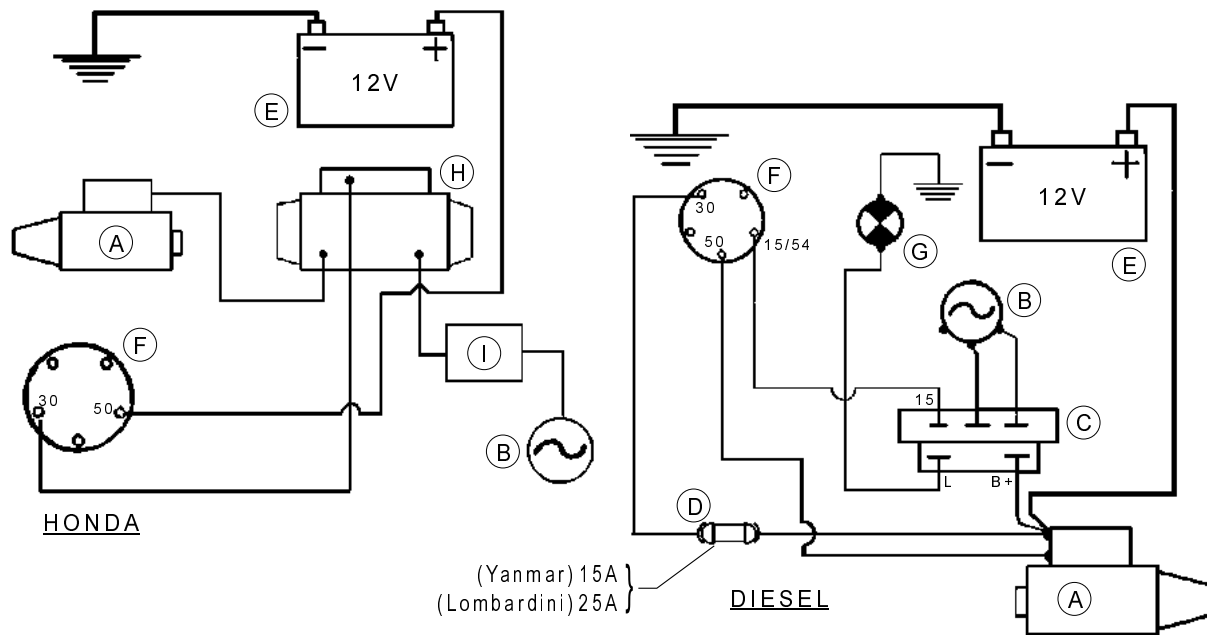

A	B	C	D
MOTORINO D'AVVIAMENTO STARTER DÉMARREUR MOT. DE ARRANQUE ANLASSMOTOR	GENERATORE GENERATOR GÉNÉRATEUR GENERADOR GENERATOR	REGOLATORE REGULATOR RÉGULATEUR REGULADOR REGLER	FUSIBILI FUSES FUSIBLES FUSIBLES SCHMELZSICHERUNGEN

E	F	G	H	I
BATTERIA BATTERY BATTERIE BATERIA BATERIE	INTERRUTTORE SWITCH INTERRUPTEUR INTERRUPTOR SCHALTER	SPIA CARICA BATTERIA BATTERY LONG WARN. LIGHT TEMOIN CHARG. BATTERIE LUZ CARGA BATERIA BATTERIELADUNG KTRL. LAMPE	SOLENOIDE SOLENOID SOLÉNOÏDE SOLENOIDE SOLENOID	DIODO DIODE DIODE DIODE DIODE

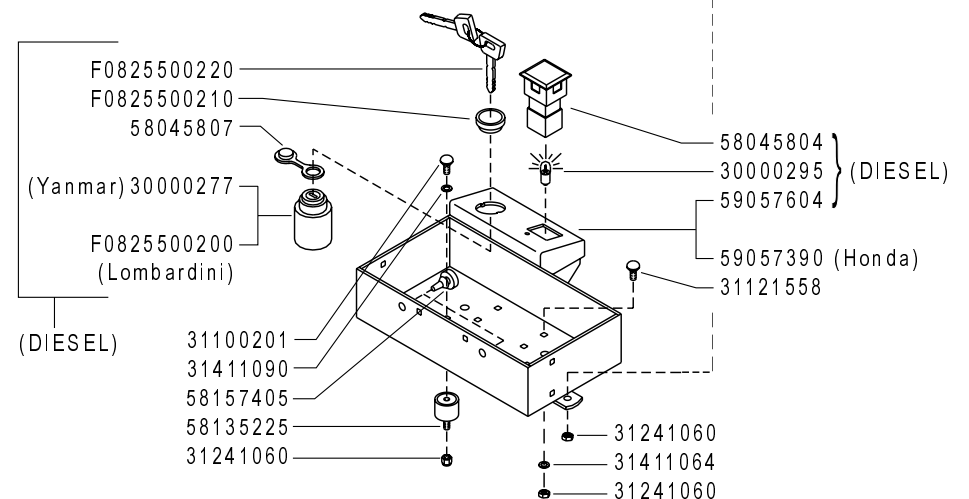

(1) sostituisce 58057610

	300 serie PS PowerSafe®	AVVIAMENTO ELETTRICO ELECTRIC STARTER ARRANQUE ELECTRICO	DALLA MACCHINA FROM THE MACHINE DE LA MACHINE DE LA MAQUINA AB DER MASCHINE	Rev.
				Q01 1
			★ N.	05/2011
			884219	

ZENNE



58056864



58056866



58057746

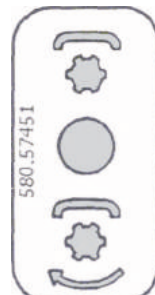

58057451



58057676



58057724



58056867



58056868

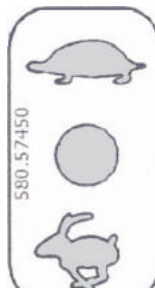

58057450

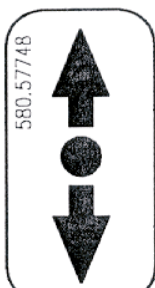

58057748



58057677



58057767



58056869

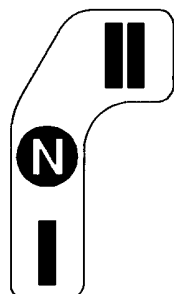

58057732



58057747

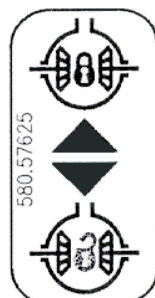

58057625



58093089



58057768

FERRARI

300 serie **PS**
PowerSafe ®

ADESIVE

STICKERS
ADHESIVOS

AUTOCOLLANTS
AUFKLEBES

DALLA MACCHINA
FROM THE MACHINE
DE LA MACHINE
DE LA MAQUINA
AB DER MASCHINE

N.

R01 0

05/2009

Rev.

ZENNE

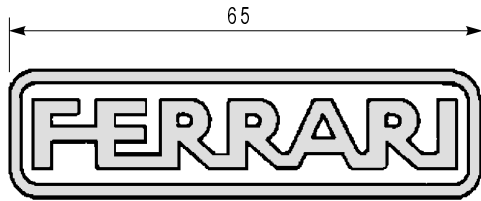

58052156



53057666

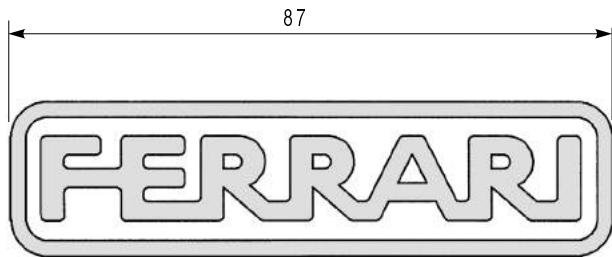

58052019

310

58052037

320

58052038

330

58052039

340

58052047

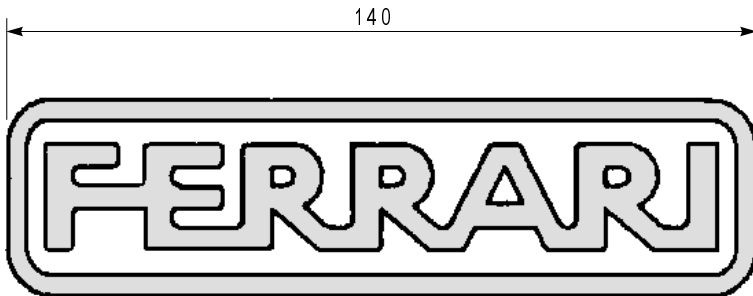

58052029

346

58052152

FERRARI

300 serie **PS**
PowerSafe ®

STICKERS
ADHESIVOS

ADESIVE

AUTOCOLLANTS
AUFKLEBES

DALLA MACCHINA
FROM THE MACHINE
DE LA MACHINE
DE LA MAQUINA
AB DER MASCHINE

N.

R02 0

05/2009

Rev.

ZENNE

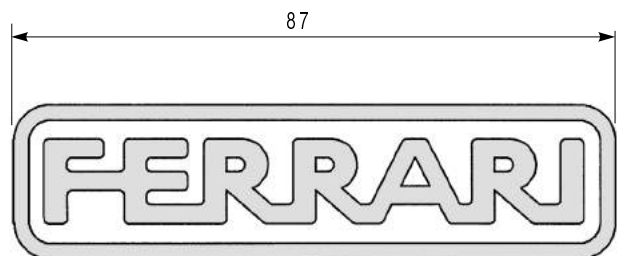

58052019

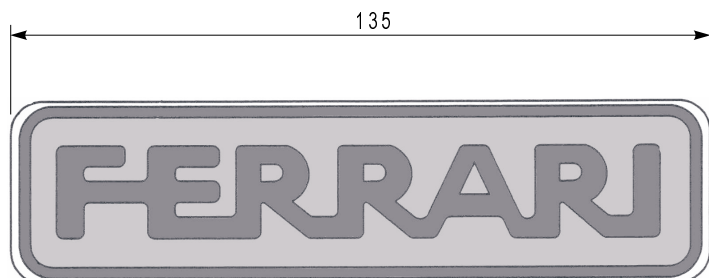

53052176 ★

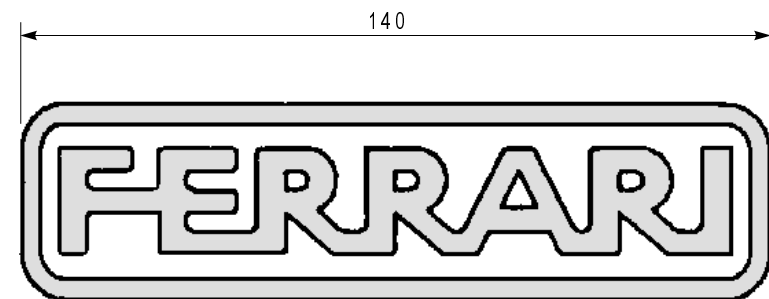

58052029



53057666



58052037



58052038



58052039



58052047



58052191 ★



58052152

FERRARI

300 serie **PS**
PowerSafe®

STICKERS
ADHESIVOS

ADESIVE

AUTOCOLLANTS
AUFKLEBES

DALLA MACCHINA
FROM THE MACHINE
DE LA MACHINE
DE LA MAQUINA
AB DER MASCHINE

AGGIORNAMENTO
REVISION
MISE A JOUR
APLAZAMIENTO
ANPASSUNG

★N.

R02

Rev.
1

11/2010

ZENNE

PowerSafe ®

1

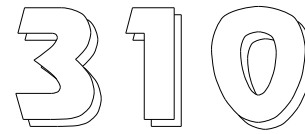

6



7

EasyDrive ®

2



8



9



3



4

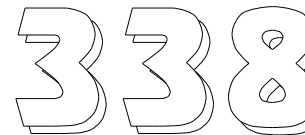

10

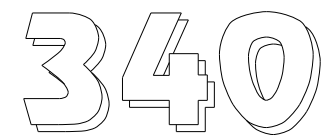

11

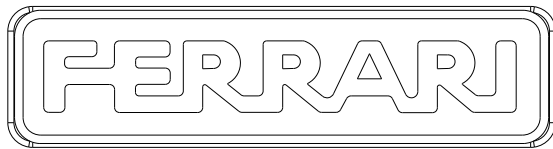

5

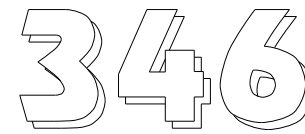

12



13

